



**AIR PURIFICATION FOR  
PHARMACEUTICALS**



## ABOUT MAYAIR

MayAir Group, a global leading manufacturer, developer and service provider of air purification equipment and clean air solutions, was established since 2001. The company specializes in air filtration research and development, design and construction, production, distribution, installation and service maintenance of clean air solutions for industrial, commercial and residential sectors.

Historically, the group's core business has been focused in providing HVAC filters, Fan Filter Units (FFUs) and air filtering equipment for the uses in industrial cleanrooms, making it one of the global leading providers in this field. With a team of a few hundreds world-class engineers, MayAir has established as one of the pioneers in air filtration product manufacturing, operating multiple manufacturing plants across the globe. With strong foundations and successful achievements in the air filtration industry across Asia, the company is rapidly expanding into the United States, Europe, Middle East, and other parts of the world.

With over 20 years of experience and continuous breakthroughs, MayAir has proven itself as a highly reliable air filtration company and developer of effective air filtration equipment and clean air solutions. It possesses the capability to offer a full spectrum of clean air solutions to various business segments, particularly in cleanrooms for the semiconductor, pharmaceutical, data centre, power plant, electrical and electronic and biomedical industries, and others.



COMPANY  
EMPLOYEES  
**900+**

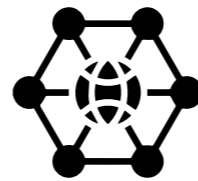

SALES  
OFFICES  
**30+**

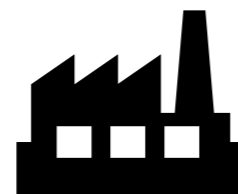

MANUFACTURING  
BASES  
**13**



R&D  
CENTERS  
**4**

## DIVERSIFIED PRODUCT RANGES & COMPREHENSIVE SOLUTIONS

### APPLICATIONS

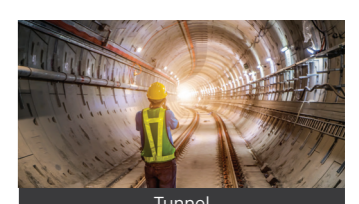
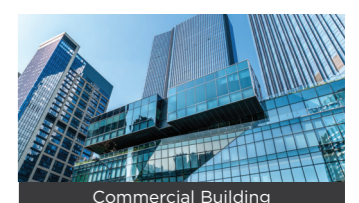
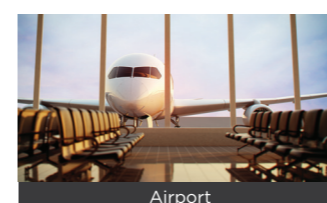

# CLEAN AIR SOLUTIONS FOR THE PHARMACEUTICAL INDUSTRY

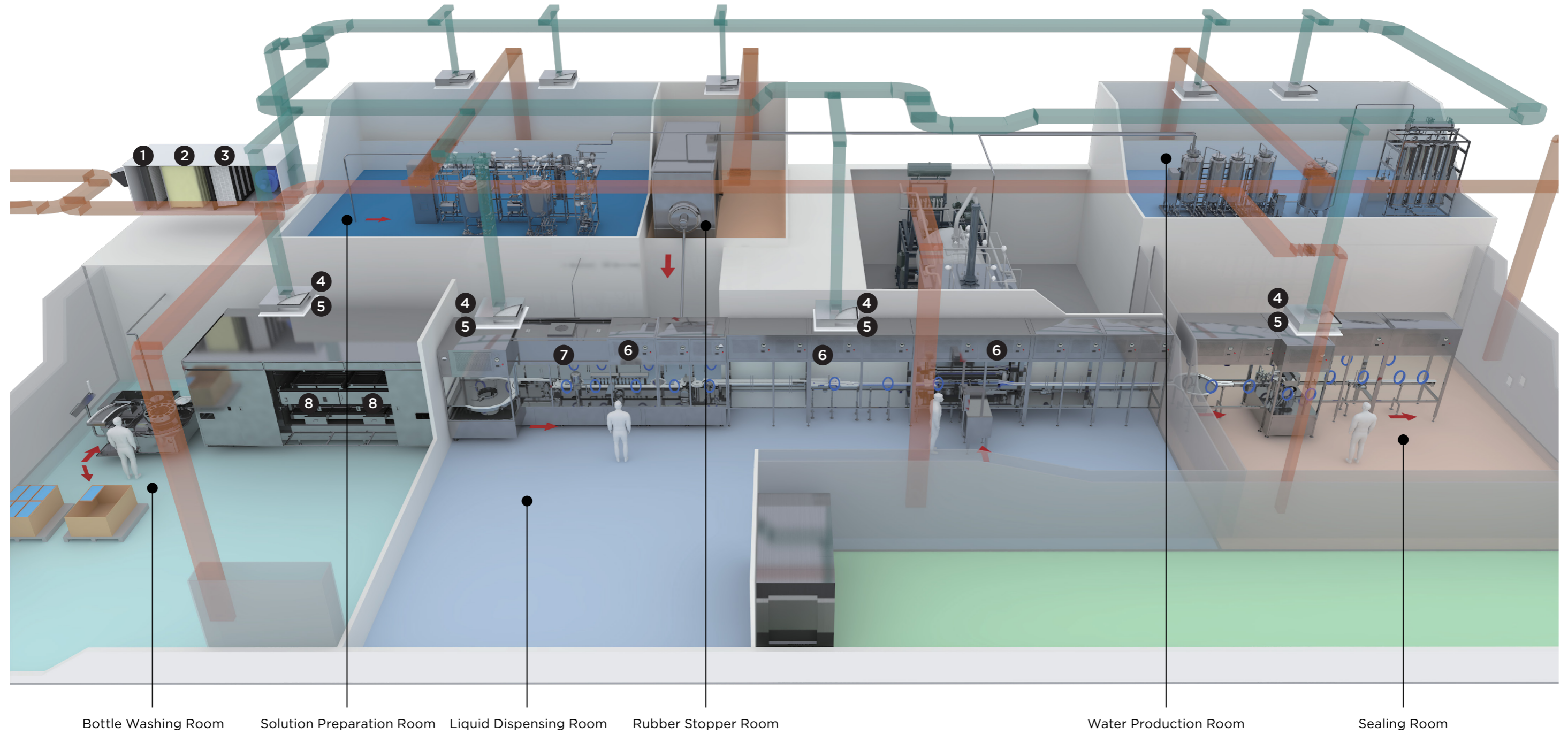

- 1



Primary Filter
- 2



Secondary Filter
- 3



V-Shaped Filter
- 4



HEPA Mini-Pleated Filter
- 5



HEPA Box
- 6



Laminar Flow Hood
- 7



Fan Filter Unit
- 8



High-Temperature Resistant HEPA Filter

## CLEAN AIR SOLUTIONS FOR THE PHARMACEUTICAL INDUSTRY

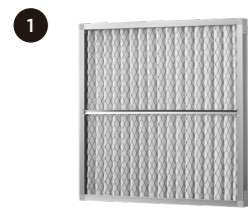
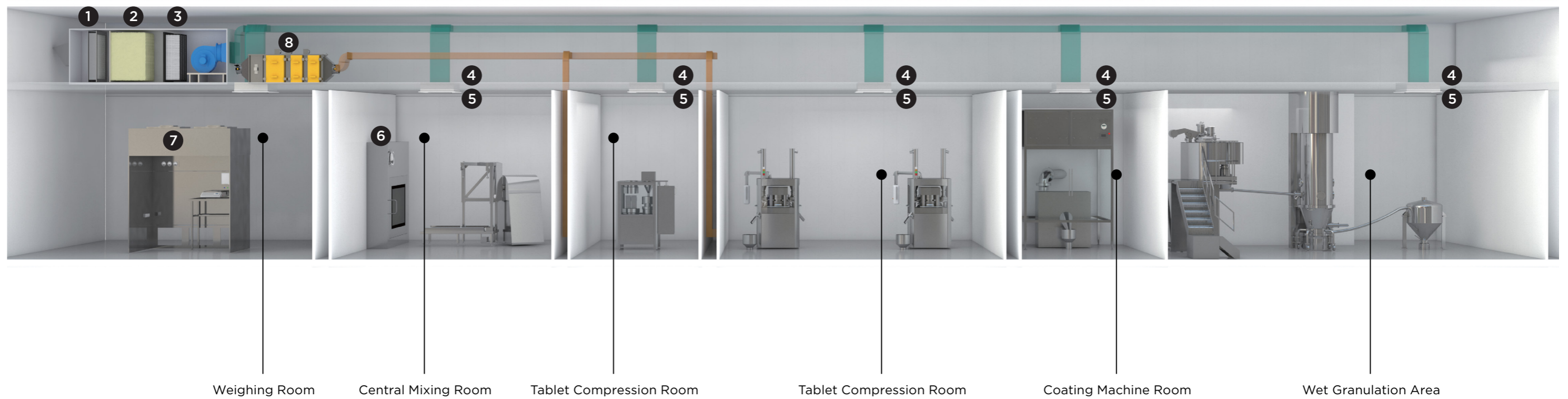

Primary Filter



Secondary Filter



V-Shaped Filter

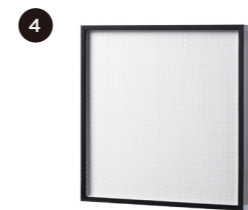

Hepa Mini-Pleated Filter



Hepa Box



Pass Box



Weighing Hood



M-BIBO (Bag-In-Bag-Out) Protective System



Laminar Flow Hood

## PRIMARY FILTER

Primary filters are primarily designed to filter out larger dust particles, extending the service life of downstream filters.

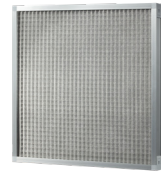

### METAL MESH FILTER M-NET

**Frame:** Aluminum alloy frame / Galvanized frame / Stainless steel

**Frame Thickness Options:** 10mm / 21mm / 23mm / 46mm / 96mm

**Filter Material:** High-strength aluminum alloy mesh / Stainless steel mesh



### DISPOSABLE FILTER M-DP

**Efficiency:** G4

**Frame:** Cardboard frame

**Frame Thickness Options:** 22mm / 44mm / 95mm

**Filter Material:** Nonwoven fabric blend with synthetic fibers



### WASHABLE FILTER M-WASH

**Efficiency:** G2, G3, G4, M5

**Frame:** Aluminum alloy / Stainless steel / Galvanized steel sheet (GI)

**Frame Thickness Options:** 10mm / 21mm / 23mm / 46mm / 96mm

**Filter Material:** High-quality polyester synthetic fiber



### WASHABLE FILTER (WIRE) MESH M-MNF

**Efficiency:** G3, G4

**Frame:** Aluminum alloy

**Frame Thickness Options:** 46mm / 96mm

**Filter Material:** High-quality polyester synthetic fiber

### PRODUCT FEATURES

- Primary filters are characterized by their compact structure, lightweight design, convenient and economical usage
- There are many types and forms, allowing customization based on specific needs
- These filters maintain consistent efficiency and low resistance over time
- Filter material options include metal mesh or high-quality synthetic fibers

| Product Specifications |  |  |                       |                                |  |      |      |                                      |
|------------------------|--|--|-----------------------|--------------------------------|--|------|------|--------------------------------------|
| Primary Filter Type    | Nominal Dimensions<br>W x H x D<br>(Inchs) | Actual Dimensions<br>W x H x D<br>(mm) | Efficiency<br>(EN779) | Airflow<br>(m <sup>3</sup> /h) | Initial Pressure Drop at Different Airflows (Pa) |      |      | Final Pressure Drop<br>(Pa)          |
|                        |  |  |                       |                                | 70%  | 100% | 120% |                                      |
| M-NET                  | 12 x 24 x 2                                | 289 x 594 x 46                         | \                     | 1,700                          | 26   | 40   | 48   | Initial Pressure Drop 2 to 2.5 times |
|                        | 24 x 24 x 2                                | 594 x 594 x 46                         | \                     | 3,400                          | 26   | 40   | 48   |                                      |
| M-DP                   | 12 x 24 x 2                                | 289 x 594 x 44                         | G4                    | 1,700                          | 56   | 86   | 110  |                                      |
|                        | 24 x 24 x 2                                | 594 x 594 x 44                         | G4                    | 3,400                          | 56   | 86   | 110  |                                      |
| M-WASH                 | 12 x 24 x 2                                | 289 x 594 x 46                         | G4                    | 1,700                          | 85   | 130  | 155  |                                      |
|                        | 24 x 24 x 2                                | 594 x 594 x 46                         | G4                    | 3,400                          | 85   | 130  | 155  |                                      |
| M-MNF                  | 12 x 24 x 2                                | 289 x 594 x 46                         | G4                    | 1,700                          | 40   | 60   | 75   |                                      |
|                        | 24 x 24 x 2                                | 594 x 594 x 46                         | G4                    | 3,400                          | 40   | 60   | 75   |                                      |

Remark:  
1. M-WASH and M-MNF filters are available with Argenzil sterilization.  
2. The above specifications outline standard options, summarized here due to space constraints.

## SECONDARY FILTER



### POCKET FILTER M-PACK (SYNTHETIC FIBER)

**Efficiency:** G3, G4, M5, M6, F7, F8, F9

**Frame:** Double-layer U-Shaped aluminum alloy / Galvanized iron sheet (GI)

**Frame Thickness Options:** 20mm / 21mm / 26mm / 47mm

**Filter Material:** synthetic fiber

**Number of Pocket:** 3P-12P

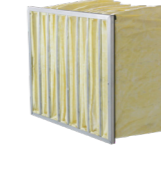

### FIBERGLASS POCKET FILTER M-PACK (FIBER GLASS)

**Efficiency:** M5, M6, F7, F8, F9

**Frame:** Double-layer U-Shaped aluminum alloy / Stainless steel / Galvanized steel sheet (GI)

**Frame Thickness Options:** 20mm / 21mm / 26mm / 47mm

**Filter Material:** Synthetic fiber

**Number of Pocket:** 3P-12P



### V-SHAPED MINI PLEATED FILTER M-MV (V-SHAPED LOW PRESSURE DROP)

**Efficiency:** M6, F7, F8, F9

**Frame:** Plastic frame / Galvanized plate / Aluminum plate

**Frame Thickness Options:** 292mm

**Filter Material:** Melt-blown non-woven fabric

**Filter Block:** 2V, 3V, 4V, 5V



### MEDIUM EFFICIENCY MINI-PLEATED FILTER M-MII (MINI-PLEATED LOW PRESSURE DROP)

**Efficiency:** M6, F7, F8, F9

**Frame:** Anodized aluminum / Galvanized steel / Stainless steel plate / Black cardboard / Aluminum plate

**Frame Thickness Options:** 20-110mm (Varies by frame material)

**Filter Material:** Melt-blown non-woven fabric

**Faceguard:** Steel mesh with plastic coating (Optional with profile or sheet metal frame)

### PRODUCT FEATURES

- **Synthetic Fiber Bag Filter:** Robust metal frame, High-quality filter media; seamless bag structure; high dust capacity; low resistance
- **Fiberglass Bag Filter:** Durable fiberglass material, riveted structure, long lifespan
- **V-Shaped Low Pressure Drop Filter:** Minimal air resistance, no-baffle design, melt-blown media for turbulence reduction, flange or flangeless options, polypropylene frames allow for incineration, high dust capacity and low air resistance
- **Low Pressure Drop Filter:** Uniform non-woven fiber media, high efficiency particulate removal, resistant to acids and alkalis

| Product Specifications      |  |  |                        |                                  |                                |  |    |    |    |     |     |     |                                      |
|-----------------------------|--|--|------------------------|----------------------------------|--------------------------------|--|----|----|----|-----|-----|-----|--------------------------------------|
| Pocket Filter Type          | Nominal Dimensions<br>W x H x D<br>(Inchs) | Actual Dimensions<br>W x H x D<br>(mm) | Pocket Number<br>(pcs) | Filter Area<br>(m <sup>2</sup> ) | Airflow<br>(m <sup>3</sup> /h) | Initial Pressure Drop at Different Airflows (Pa) |    |    |    |     |     |     | Final Pressure Drop<br>(Pa)          |
|                             |  |  |                        |                                  |                                | G3   | G4 | M5 | M6 | F7  | F8  | F9  |                                      |
| M-PACK<br>(Synthetic fiber) | 24 x 24 x 25                               | 594 x 594 x 635                        | 8                      | 6.60                             | 3,400                          | 37   | 45 | 55 | 58 | 90  | 95  | 125 | Initial pressure drop 2 to 2.5 times |
|                             | 20 x 24 x 25                               | 490 x 594 x 635                        | 6                      | 4.94                             | 2,850                          | 37   | 45 | 55 | 58 | 90  | 95  | 125 |                                      |
| M-PACK<br>(Fiber glass)     | 24 x 24 x 24                               | 594 x 594 x 600                        | 8                      | 6                                | 3,400                          | \  | \  | 80 | 95 | 110 | 130 | 150 |                                      |
|                             | 20 x 24 x 24                               | 490 x 594 x 600                        | 6                      | 4.5                              | 2,800                          | \  | \  | 80 | 95 | 110 | 130 | 150 |                                      |

| Secondary Filter Type                     | Dimensions<br>W x H x D<br>(mm) | Flange        | Airflow<br>(m <sup>3</sup> /h) | Initial Pressure Drop at Different Airflows (Pa) |    |    |    | Recommended Final Pressure Drop<br>(Pa) |
|---|---------------------------------|---------------|--------------------------------|--|----|----|----|---|
|   |                                 |               |                                | M6   | F7 | F8 | F9 |   |
| M-MV<br>(V-Shaped low-pressure drop)      | 287 x 592 x 292                 | Single flange | 1,200                          | 65   | 70 | 75 | 85 | Initial pressure drop 2 to 2.5 times    |
|   | 305 x 610 x 292                 | Non flange    | 1,400                          | 65   | 70 | 75 | 85 |   |
| M-MII<br>(Mini pleated low-pressure drop) | 305 x 610 x 30                  | Non flange    | 1,400                          | 25   | 45 | 60 | 75 |   |
|   | 305 x 610 x 50                  | Non flange    | 1,400                          | 25   | 45 | 60 | 75 |   |

Remark:  
1. M-MV (V-shaped, low-pressure drop) and M-MII (baffle-free, low-pressure drop) filters can undergo argenzil sterilization.  
2. V-shaped or baffle-free low-pressure drop filters can achieve sub-high efficiency.





## M-MI MEDIUM EFFICIENCY SECONDARY FILTER WITH SEPERATOR

### PRODUCT FEATURES

- Aluminum partitions with frame options available in non-flanged, single-flanged, and double-flanged designs, with a flange thickness of 20mm
- Utilizes ultra-fine fiberglass filter paper
- Designed with separators to ensure high efficiency, low resistance, and excellent dust-holding capacity
- Suitable for variable air volume (VAV) systems

### APPLICATIONS

- Medium efficiency filters for cleanrooms and HVAC systems in pharmaceutical facilities
- Suitable for HVAC systems operating under high humidity and variable air volume (VAV) conditions
- Ideal for ventilation systems with stringent fire protection requirements or elevated air temperatures
- Applicable to localized pharmaceutical equipment, such as ambient-temperature filtration in ovens

### EFFICIENCY

- M6, F7, F8, F9

### PRODUCT STRUCTURE DESCRIPTION

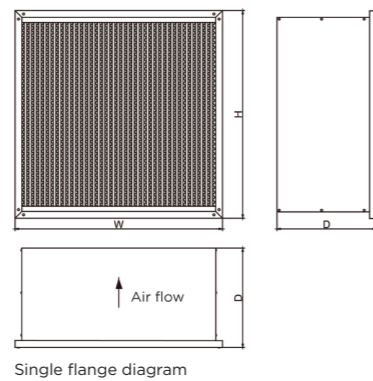

### NAME SPECIFICATION

MI - 01 - □□□ - □□□ - □□ - E□ - □□ - □ - □

- Separator types: Not labeled-Aluminum separator, Z-Paper separator
- Airflow type: N-Standard airflow, H-High airflow, HL-High airflow with low pressure drop
- Flange types: X-No flange, D1-Single flange, D2-Double flange
- Air-tight gasket: E0-None, E1-Inlet side, E2-Double-sided, E3-Outlet side
- Frame material: SS-SUS304 (stainless steel sheet), SG-SGCC (galvanized steel sheet), AL-aluminum (aluminum sheet)
- Dimensions: Width x Height x Depth (WxHxD), unit: mm
- Efficiency: M6, F7, F8, F9
- Manufacturer: MayAir
- Type: Medium efficiency secondary filter with separator

### INITIAL PRESSURE DROP VS. AIRFLOW

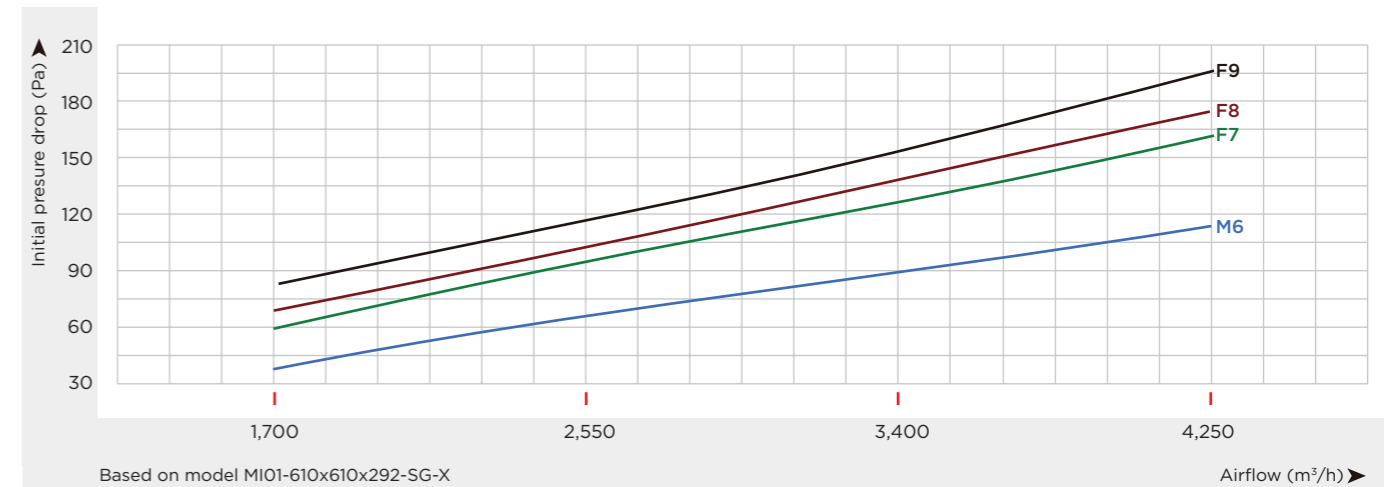

| Materials Table |  |
|-----------------|--|
| Frame           | Galvanized steel sheet / Aluminum sheet / Stainless steel sheet / Aluminum profile |
| Thickness       | 80mm / 150mm / 220mm / 292mm   |
| Filter Material | Ultrafine Glass Fiber  |
| Separator       | Aluminum foil / Paper  |
| Gasket          | Polyurethane   |

Note: Faceguard available (Material: PVC-coated steel mesh)

| Applicable Conditions |              |
|-----------------------|--------------|
| Maximum Temperature   | 70°C (158°F) |

| Product Specifications                    |  |          |        |                   |                           |                                     |     |     |     |  |
|---|--|----------|--------|-------------------|---------------------------|-------------------------------------|-----|-----|-----|--|
| Nominal Dimensions<br>W x H x D<br>(Inch) | Actual Dimensions<br>W x H x D<br>(mm) | Pleated  | Flange | Airflow<br>(m³/h) | Face<br>Velocity<br>(m/s) | Rated Initial Pressure Drop<br>(Pa) |     |     |     | Recommended<br>Final Pressure Drop<br>(Pa) |
|   |  |          |        |                   |                           | M6                                  | F7  | F8  | F9  |  |
| 12 x 24 x 3                               | 305 x 610 x 80                         | Aluminum | None   | 400               | 0.6                       | 90                                  | 130 | 140 | 150 | 300  |
| 24 x 24 x 3                               | 610 x 610 x 80                         |          |        | 800               | 0.6                       | 90                                  | 130 | 140 | 150 | 300  |
| 12 x 24 x 6                               | 305 x 610 x 150                        |          |        | 650               | 1.2                       | 90                                  | 130 | 140 | 150 | 300  |
| 24 x 24 x 6                               | 610 x 610 x 150                        |          |        | 1,400             | 1.2                       | 90                                  | 130 | 140 | 150 | 300  |
| 12 x 24 x 9                               | 305 x 610 x 220                        |          |        | 860               | 1.6                       | 90                                  | 130 | 140 | 150 | 300  |
| 24 x 24 x 9                               | 610 x 610 x 220                        |          |        | 1,860             | 1.6                       | 90                                  | 130 | 140 | 150 | 300  |
| 12 x 24 x 12                              | 305 x 610 x 292                        |          |        | 1,400             | 2.5                       | 90                                  | 130 | 140 | 150 | 300  |
| 24 x 24 x 12                              | 610 x 610 x 292                        |          |        | 3,000             | 2.5                       | 90                                  | 130 | 140 | 150 | 300  |

Remark:  
1. Initial pressure drop performance tolerance is ±10%  
2. Special dimensions available upon request



## M-SHI SEMI-HIGH EFFICIENCY SEMI-HEPA FILTER WITH SEPARATOR

### PRODUCT FEATURES

- Aluminum partitions with frames available in non-flanged, single flanged, and double-flanged options, with a flange thickness of 20mm
- Utilizes ultra-fine fiberglass filter paper
- Designed with separator to ensure high efficiency, low resistance and excellent dust-holding capacity
- Suitable for variable air volume (VAV) systems

### APPLICATIONS

- Medium-efficiency filters for cleanroom and HVAC systems in pharmaceutical facilities
- Suitable for HVAC systems operating under high humidity and variable air volume (VAV) conditions
- Ideal for ventilation systems requiring stringent fire protection or capable of handling elevated air temperatures
- Applicable to localized pharmaceutical equipment, such as ambient temperature filtration in ovens

### EFFICIENCY

- E10, E11, E12

### PRODUCT STRUCTURE DESCRIPTION

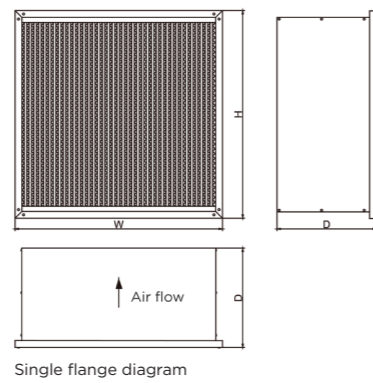

| Materials Table |  |
|-----------------|--|
| Frame           | Galvanized steel sheet / Aluminum sheet / Stainless steel sheet / Aluminum profile |
| Thickness       | 80mm / 150mm / 220mm / 292mm   |
| Filter Material | Ultrafine Glass Fiber  |
| Separator       | Aluminum foil / Paper  |
| Gasket          | Polyurethane   |

Note: Faceguard available (Material: PVC-coated steel mesh)

| Applicable Conditions |              |
|-----------------------|--------------|
| Maximum Temperature   | 70°C (158°F) |

### NAME SPECIFICATION

SHI - 01 - □□□ - □□□ - □□ - E□ - □□ - □ - □

- Separator types: Not labeled-Aluminum separator, Z-Paper separator
- Airflow type: N-Standard airflow, H-High airflow, HL-High airflow with low pressure drop
- Flange types: X-No flange, D1-Single flange, D2-Double flange
- Air-tight gasket: E0-None, E1-Inlet side, E2-Double-sided, E3-Outlet side
- Frame material: SS-SUS304 (stainless steel sheet), SG-SGCC (galvanized steel sheet), AL-aluminum (aluminum sheet)
- Dimensions: Width x Height x Depth (WxHxD), unit: mm
- Efficiency: E10, E11, E12
- Manufacturer: MayAir
- Type: Semi-high efficiency semi-HEPA filter with separator

### INITIAL PRESSURE DROP VS. AIRFLOW

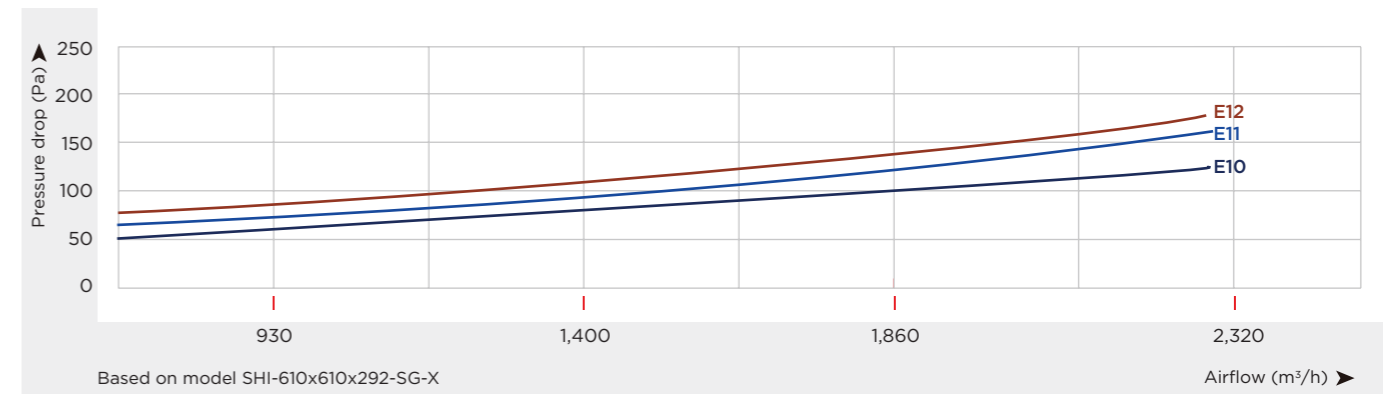

| Product Specifications                    |  |           |        |                   |                           |                                     |     |     |  |
|---|--|-----------|--------|-------------------|---------------------------|-------------------------------------|-----|-----|--|
| Nominal Dimensions<br>W x H x D<br>(Inch) | Actual Dimensions<br>W x H x D<br>(mm) | Separator | Flange | Airflow<br>(m³/h) | Face<br>Velocity<br>(m/s) | Rated Initial Pressure Drop<br>(Pa) |     |     | Recommended<br>Final Pressure Drop<br>(Pa) |
|   |  |           |        |                   |                           | E10                                 | E11 | E12 |  |
| 12 x 24 x 3                               | 305 x 610 x 80                         | Aluminum  | None   | 200               | 0.36                      | 100                                 | 130 | 140 | 450  |
| 24 x 24 x 3                               | 610 x 610 x 80                         |           |        | 420               | 0.36                      | 100                                 | 130 | 140 | 450  |
| 12 x 24 x 6                               | 305 x 610 x 150                        |           |        | 420               | 0.77                      | 100                                 | 130 | 140 | 450  |
| 24 x 24 x 6                               | 610 x 610 x 150                        |           |        | 900               | 0.77                      | 100                                 | 130 | 140 | 450  |
| 12 x 24 x 9                               | 305 x 610 x 220                        |           |        | 650               | 1.20                      | 100                                 | 130 | 140 | 450  |
| 24 x 24 x 9                               | 610 x 610 x 220                        |           |        | 1,400             | 1.20                      | 100                                 | 130 | 140 | 450  |
| 12 x 24 x 12                              | 305 x 610 x 292                        |           |        | 860               | 1.60                      | 100                                 | 130 | 140 | 450  |
| 24 x 24 x 12                              | 610 x 610 x 292                        |           |        | 1,860             | 1.60                      | 100                                 | 130 | 140 | 450  |

Remark:  
1. Initial pressure drop performance tolerance is ±10%  
2. Special dimensions available upon request

# M-HI HIGH-EFFICIENCY HEPA FILTER WITH SEPARATOR

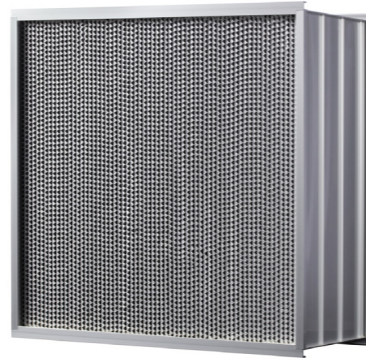

## PRODUCT FEATURES

- Aluminum partitions with frames available in non-flanged, single flanged, and double-flanged options, with a flange thickness of 20mm
- Utilizes ultra-fine fiberglass filter paper
- Designed with separator to ensure high efficiency, low resistance and excellent dust-holding capacity
- Suitable for variable air volume (VAV) systems

## APPLICATIONS

- Medium-efficiency filters for cleanrooms and HVAC systems in pharmaceutical facilities
- Suitable for HVAC systems operating under high humidity and VAV conditions
- Ideal for ventilation systems with stringent fire protection requirements or elevated air temperatures
- Applicable to localized pharmaceutical equipment, such as ambient temperature filtration in ovens

## EFFICIENCY

- 99.95%@MPPS(H13), 99.995%@MPPS(H14)

## PRODUCT STRUCTURE DESCRIPTION

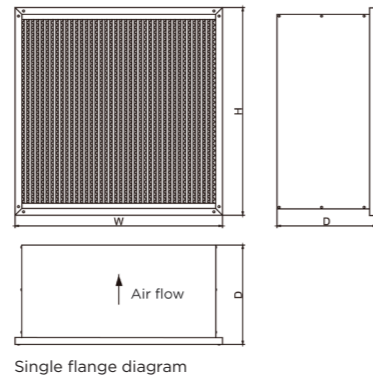

| Materials Table |  |
|-----------------|--|
| Frame           | Galvanized steel sheet / Aluminum sheet / Stainless steel sheet / Aluminum profile |
| Thickness       | 80mm / 150mm / 220mm / 292mm   |
| Filter Material | Ultrafine glass fiber  |
| Separator       | Aluminum foil / Paper  |
| Gasket          | Polyurethane   |

Note: Faceguard available (Material: PVC-coated steel mesh)

| Applicable Conditions |              |
|-----------------------|--------------|
| Maximum Temperature   | 70°C (158°F) |

## NAME SPECIFICATION

HI - 01 - □□□ - □□□ - □□ - E□ - □□ - □ - □

- Separator types: Not labeled-Aluminum separator, Z-Paper separator
- Airflow type: N-Standard airflow, H-High airflow, HL-High airflow with low pressure drop
- Flange types: X-No flange, D1-Single flange, D2-Double flange
- Air-tight gasket: E0-None, E1-Inlet side, E2-Double-sided, E3-Outlet side
- Frame material: SS-SUS304 (stainless steel sheet), SG-SGCC (galvanized steel sheet), AL-Aluminum (aluminum sheet)
- Dimensions: Width x Height x Depth (WxHxD), unit: mm
- Efficiency: H13, H14
- Manufacturer: MayAir
- Type: High-efficiency HEPA filter with separator

## INITIAL PRESSURE DROP VS. AIRFLOW VELOCITY

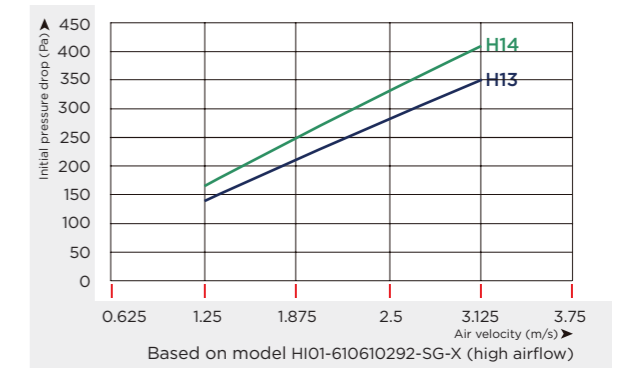
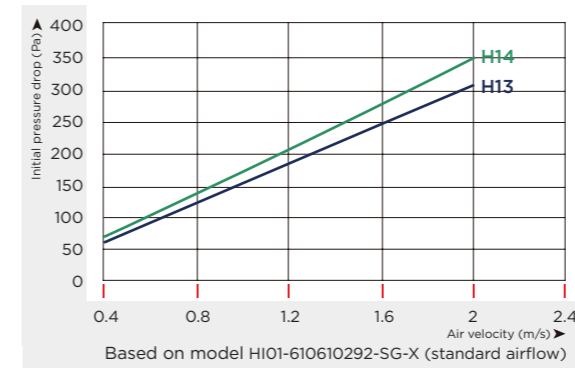

| M-HI Product Specifications: HEPA Filter with Separator - Standard Airflow |  |           |        |                   |                        |                                     |     |  |
|--|--|-----------|--------|-------------------|------------------------|-------------------------------------|-----|--|
| Nominal Dimensions<br>W x H x D<br>(Inch)                                  | Actual Dimensions<br>W x H x D<br>(mm) | Separator | Flange | Airflow<br>(m³/h) | Face Velocity<br>(m/s) | Rated Initial Pressure Drop<br>(Pa) |     | Recommended<br>Final Pressure Drop<br>(Pa) |
|  |  |           |        |                   |                        | H13                                 | H14 |  |
| 12 x 24 x 3  | 305 x 610 x 80                         | Aluminum  | None   | 200               | 0.36                   | 249                                 | 280 | Initial pressure drop<br>2 to 2.5 times    |
| 24 x 24 x 3  | 610 x 610 x 80                         |           |        | 420               | 0.36                   | 249                                 | 280 |  |
| 12 x 24 x 6  | 305 x 610 x 150                        |           |        | 420               | 0.77                   | 249                                 | 280 |  |
| 24 x 24 x 6  | 610 x 610 x 150                        |           |        | 900               | 0.77                   | 249                                 | 280 |  |
| 12 x 24 x 9  | 305 x 610 x 220                        |           |        | 650               | 1.20                   | 249                                 | 280 |  |
| 24 x 24 x 9  | 610 x 610 x 220                        |           |        | 1,400             | 1.20                   | 249                                 | 280 |  |
| 12 x 24 x 12   | 305 x 610 x 292                        |           |        | 860               | 1.60                   | 249                                 | 280 |  |
| 24 x 24 x 12   | 610 x 610 x 292                        |           |        | 1,860             | 1.60                   | 249                                 | 280 |  |

| M-HI Product Specifications: HEPA Filter with Separator - High Airflow |  |           |        |                   |                        |                                     |     |  |
|--|--|-----------|--------|-------------------|------------------------|-------------------------------------|-----|--|
| Nominal Dimensions<br>W x H x D<br>(Inch)                              | Actual Dimensions<br>W x H x D<br>(mm) | Separator | Flange | Airflow<br>(m³/h) | Face Velocity<br>(m/s) | Rated Initial Pressure Drop<br>(Pa) |     | Recommended<br>Final Pressure Drop<br>(Pa) |
|  |  |           |        |                   |                        | H13                                 | H14 |  |
| 12 x 24 x 3  | 305 x 610 x 80                         | Aluminum  | None   | 400               | 0.60                   | 249                                 | 280 | Initial pressure drop<br>2 to 2.5 times    |
| 24 x 24 x 3  | 610 x 610 x 80                         |           |        | 800               | 0.60                   | 249                                 | 280 |  |
| 12 x 24 x 6  | 305 x 610 x 150                        |           |        | 550               | 1.00                   | 249                                 | 280 |  |
| 24 x 24 x 6  | 610 x 610 x 150                        |           |        | 1,170             | 1.00                   | 249                                 | 280 |  |
| 12 x 24 x 9  | 305 x 610 x 220                        |           |        | 850               | 1.55                   | 249                                 | 280 |  |
| 24 x 24 x 9  | 610 x 610 x 220                        |           |        | 1,820             | 1.55                   | 249                                 | 280 |  |
| 12 x 24 x 12   | 305 x 610 x 292                        |           |        | 1,120             | 2.00                   | 249                                 | 280 |  |
| 24 x 24 x 12   | 610 x 610 x 292                        |           |        | 2,400             | 2.00                   | 249                                 | 280 |  |

| M-HI Product Specifications: HEPA Filter with Separator - High Airflow Low Pressure Drop |  |           |        |                   |                        |                                     |     |  |
|--|--|-----------|--------|-------------------|------------------------|-------------------------------------|-----|--|
| Nominal Dimensions<br>W x H x D<br>(Inch)  | Actual Dimensions<br>W x H x D<br>(mm) | Separator | Flange | Airflow<br>(m³/h) | Face Velocity<br>(m/s) | Rated Initial Pressure Drop<br>(Pa) |     | Recommended<br>Final Pressure Drop<br>(Pa) |
|  |  |           |        |                   |                        | H13                                 | H14 |  |
| 12 x 24 x 12   | 305 x 610 x 292                        | Aluminum  | None   | 1,400             | 2.50                   | 330                                 | 380 | Initial pressure drop<br>2 to 2.5 times    |
| 24 x 12 x 12   | 610 x 610 x 292                        |           |        | 3,000             | 2.50                   | 330                                 | 380 |  |

- Remark:
- Initial pressure drop performance tolerance is ±10%.
  - Special dimensions available upon request.

## M-MV MEDIUM EFFICIENCY V-SHAPED MINI-PLEATED FILTER

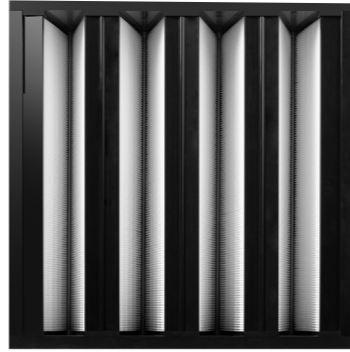

### PRODUCT FEATURES

- V-shaped, low pressure drop filter
- Separatorless design with ultrafine glass fiber media
- High dust holding capacity, low resistance, and long service life
- Durable construction ensures stable performance under turbulent airflow conditions
- Polypropylene frame is fully incinerable for safe disposal

### APPLICATIONS

- Medium efficiency filter for cleanrooms and HVAC systems in pharmaceutical facilities
- HVAC systems in high-humidity and variable air volume (VAV) environments
- HVAC systems with limited installation space and low resistance requirements

### EFFICIENCY

- M6, F7, F8, F9

### PRODUCT STRUCTURE DESCRIPTION

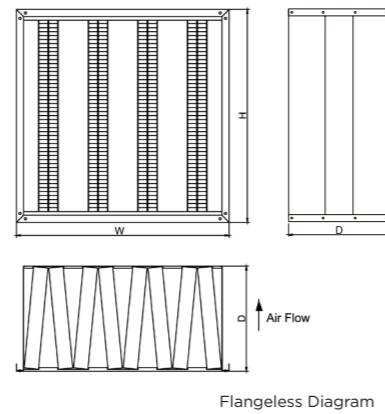

### NAME SPECIFICATION

MV - 01 - □□□ - □□□ - □ - □□ - E□ - □□ - □

- 1 Airflow type: N-Standard airflow, H-High airflow
- 2 Enclosure type: X-Non-flange, D1-Single flange
- 3 Air-tight gasket: E0-None, E1-Inlet side, E2-Both sides, E3-Outlet side
- 4 Frame material: PL-Plastic frame, SG (galvanized steel sheet), AL-Aluminum (aluminum sheet)
- 5 Filter: 2-2V, 3-3V, 4-4V, 5-5V
- 6 Dimensions: Width x Height x Depth (WxHxD), unit: mm
- 7 Efficiency: M6, F7, F8, F9
- 8 Manufacturer: MayAir
- 9 Type: Medium efficiency V-Shaped mini-pleated filter

### INITIAL PRESSURE DROP VS. AIRFLOW

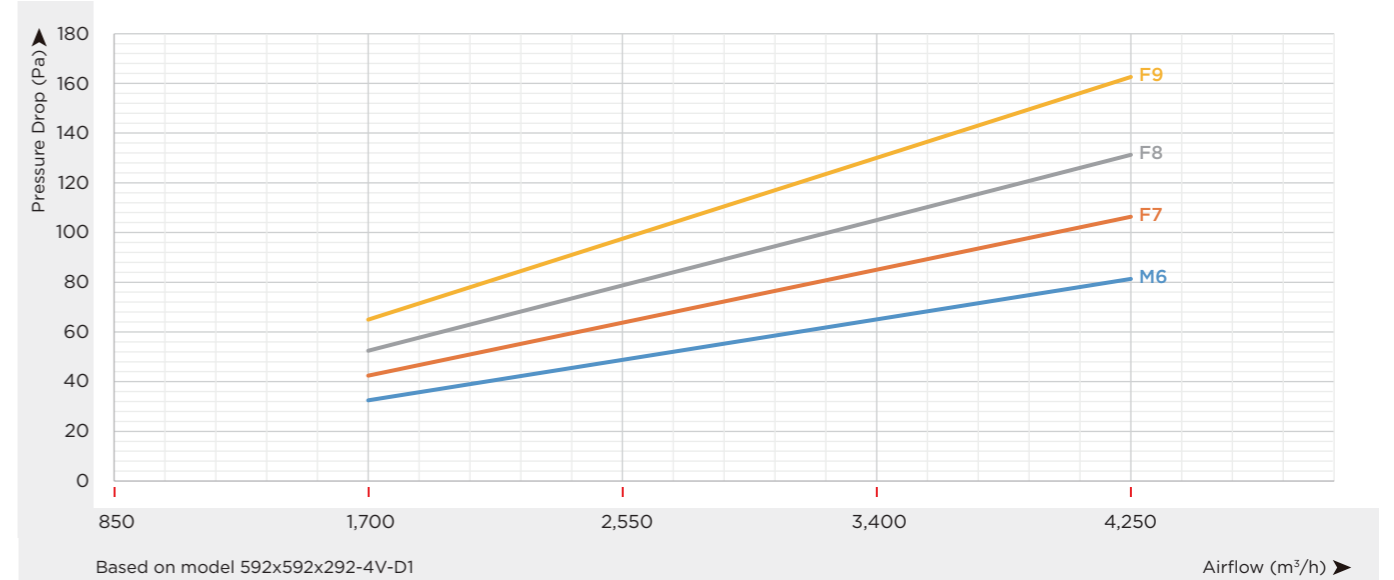

| Materials Table |   |
|-----------------|---|
| Frame           | ABS / Galvanized steel sheet / Aluminum |
| Thickness       | 292mm                                   |
| Filter Material | Ultrafine glass fiber                   |
| Separator       | Hot melt adhesive                       |
| Gasket          | Polyurethane                            |

| Applicable Conditions |              |
|-----------------------|--------------|
| Maximum Temperature   | 70°C (158°F) |

| Nominal Dimensions<br>W x H x D<br>(Inch) | Actual Dimensions<br>W x H x D<br>(mm) | Filter Block<br>(V) | Flange<br>(Material)   | Airflow<br>(m³/h) | Rated Initial Pressure Drop<br>(Pa) |    |     |     | Recommended<br>Final Pressure Drop<br>(Pa) |
|---|--|---------------------|------------------------|-------------------|-------------------------------------|----|-----|-----|--|
|   |  |                     |                        |                   | M5                                  | F7 | F8  | F9  |  |
| 12 x 24 x 12                              | 287 x 592 x 292                        | 2V                  | Single flange<br>(ABS) | 1,700             | 65                                  | 85 | 105 | 130 | 450  |
| 24 x 12 x 12                              | 592 x 287 x 292                        | 4V                  |                        | 1,700             | 65                                  | 85 | 105 | 130 | 450  |
| 24 x 20 x 12                              | 592 x 490 x 292                        | 4V                  |                        | 2,800             | 65                                  | 85 | 105 | 130 | 450  |
| 24 x 24 x 12                              | 592 x 592 x 292                        | 4V                  |                        | 3,400             | 65                                  | 85 | 105 | 130 | 450  |

Note: Performance initial pressure drop tolerance is ±10%.

# M-SHV SEMI-HIGH EFFICIENCY V-SHAPED MINI-PLEATED AIR FILTER



## PRODUCT FEATURES

- V-shaped, low pressure drop filter
- Separatorless design with ultrafine glass fiber media
- High dust holding capacity, low resistance, and long service life
- Durable construction ensures stable performance under turbulent airflow conditions
- Polypropylene frame is fully incinerable for safe disposal

## APPLICATIONS

- Medium efficiency filter for cleanrooms and HVAC systems in pharmaceutical facilities
- HVAC systems in high-humidity and variable air volume (VAV) environments
- HVAC systems with limited installation space and low resistance requirements

## EFFICIENCY

- E10, E11, E12

## PRODUCT STRUCTURE DESCRIPTION

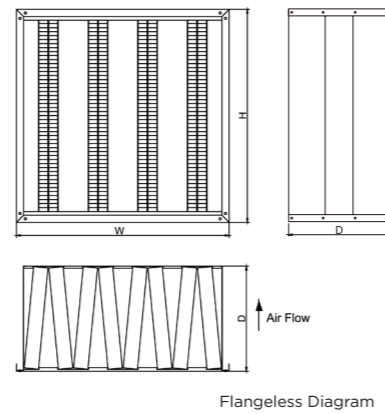

| Materials Table       |   |
|-----------------------|---|
| Frame                 | ABS / Galvanized steel sheet / Aluminum |
| Thickness             | 292mm                                   |
| Filter Material       | Water-resistant fiberglass              |
| Separator             | Hot melt adhesive                       |
| Gasket                | Polyurethane                            |
| Applicable Conditions |   |
| Maximum Temperature   | 70°C (158°F)                            |

## NAME SPECIFICATION

SHV - 01 - □□□ - □□□ - □ - □□ - E□ - □□ - □

- 1 Airflow type: N-Standard airflow, H-High airflow
- 2 Enclosure type: X-Non-flange, D1-Single flange
- 3 Air-tight gasket: E0-None, E1-Inlet side, E2-Both sides, E3-Outlet side
- 4 Frame material: PL-Plastic frame, SG (galvanized steel sheet), AL-Aluminum (aluminum sheet)
- 5 Filter: 2-2V, 3-3V, 4-4V, 5-5V
- 6 Dimensions: Width x Height x Depth (WxHxD), unit: mm
- 7 Efficiency: E10, E11, E12
- 8 Manufacturer: MayAir
- 9 Type: Medium efficiency V-shaped mini-pleated filter

## INITIAL PRESSURE DROP VS. AIRFLOW

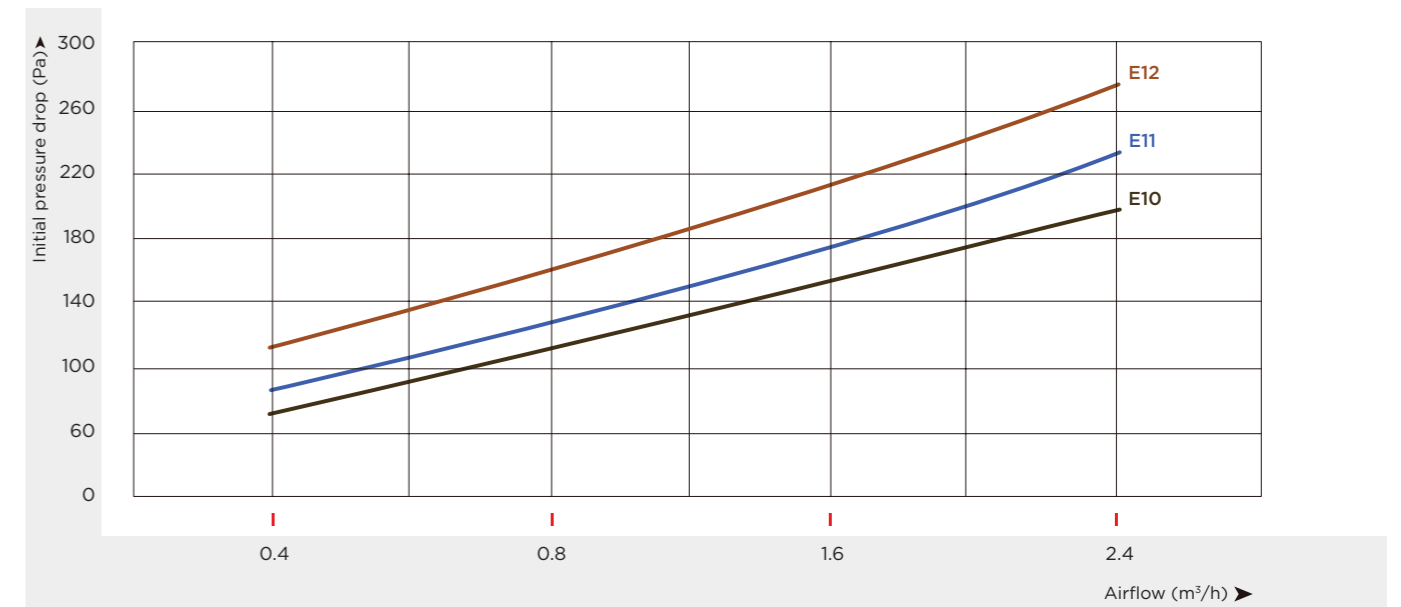

| Product Specifications : Standard Series  |  |                        |                                      |                            |                           |                                     |     |     |  |
|---|--|------------------------|--------------------------------------|----------------------------|---------------------------|-------------------------------------|-----|-----|--|
| Nominal Dimensions<br>W x H x D<br>(Inch) | Actual Dimensions<br>W x H x D<br>(mm) | Filter<br>Block<br>(V) | Flange<br>(None / Single)            | Rated<br>Airflow<br>(m³/h) | Face<br>Velocity<br>(m/s) | Rated Initial Pressure Drop<br>(Pa) |     |     | Recommended<br>Final Pressure Drop<br>(Pa) |
|   |  |                        |                                      |                            |                           | E10                                 | E11 | E12 |  |
| 12 x 24 x 12                              | 287 x 592 x 292                        | 2                      | Single Flange /<br>Sheet Metal Frame | 1,200                      | 2.5                       | 150                                 | 180 | 215 | 450  |
| 24 x 12 x 12                              | 592 x 287 x 292                        | 4                      |                                      | 1,200                      | 2.5                       | 150                                 | 180 | 215 | 450  |
| 24 x 20 x 12                              | 592 x 490 x 292                        | 4                      |                                      | 2,200                      | 2.5                       | 150                                 | 180 | 215 | 450  |
| 24 x 24 x 12                              | 592 x 592 x 292                        | 4                      |                                      | 2,700                      | 2.5                       | 150                                 | 180 | 215 | 450  |
| 12 x 24 x 12                              | 305 x 610 x 292                        | 2                      |                                      | 1,400                      | 2.5                       | 120                                 | 150 | 185 | 450  |
| 24 x 24 x 12                              | 610 x 610 x 292                        | 4                      |                                      | 3,000                      | 2.5                       | 120                                 | 150 | 185 | 450  |

Note: Performance initial pressure drop tolerance is ±10%.

# M-HV HIGH EFFICIENCY V-SHAPED MINI-PLEATED FILTER



## PRODUCT FEATURES

- V-shaped, low pressure drop design
- Separatorless construction with ultrafine glass fiber media
- High dust holding capacity, low resistance, and extended service life
- Durable construction ensures stable performance under turbulent airflow conditions
- Polypropylene frame is fully incinerable for safe disposal

## APPLICATIONS

- Medium efficiency filter for cleanrooms and HVAC systems in pharmaceutical facilities
- Suitable for HVAC systems operating in high-humidity and variable air volume (VAV) environments
- Ideal for HVAC systems with limited installation space and low resistance requirements

## EFFICIENCY

- 99.95%@MPPS(H13), 99.995%@MPPS(H14)

## PRODUCT STRUCTURE DESCRIPTION

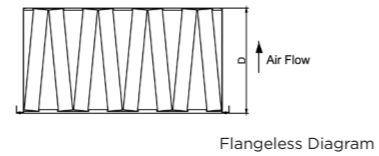
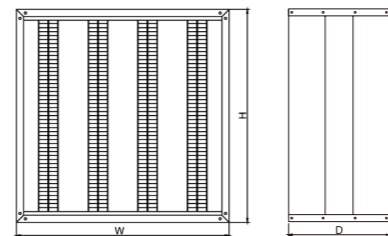

| Materials Table |   |
|-----------------|---|
| Frame           | ABS / Galvanized steel sheet / Aluminum |
| Thickness       | 292mm                                   |
| Filter Material | Water-resistant fiberglass              |
| Separator       | Hot melt adhesive                       |
| Gasket          | Polyurethane                            |

| Applicable Conditions |              |
|-----------------------|--------------|
| Maximum Temperature   | 70°C (158°F) |

## NAME SPECIFICATION

HV - 01 - □□□ - □□□ - □□□ - E□ - □□ - □

- 1 Airflow type: N-Standard airflow, H-High airflow
- 2 Enclosure type: X-Non-flange, D1-Single flange
- 3 Air-tight gasket: E0-None, E1-Inlet side, E2-Both sides, E3-Outlet side
- 4 Frame material: PL-Plastic frame, SG (galvanized steel sheet), AL-aluminum (aluminum sheet)
- 5 Filter: 2-2V, 3-3V, 4-4V, 5-5V
- 6 Dimensions: Width x Height x Depth (WxHxD), unit: mm
- 7 Efficiency: H13, H14
- 8 Manufacturer: MayAir
- 9 Type: High efficiency V-Shaped mini-pleated filter

## INITIAL PRESSURE DROP VS. AIRFLOW VELOCITY

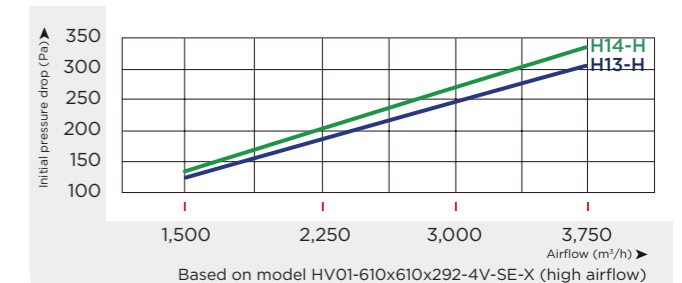
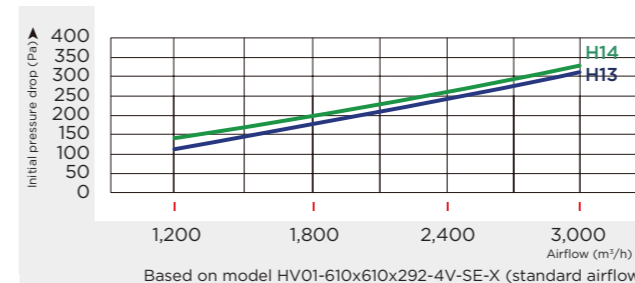

| Product Specifications : HEPA Mini Pleated Filter-Standard Airflow Series |  |                        |                           |                            |                           |                                     |     |  |
|---|--|------------------------|---------------------------|----------------------------|---------------------------|-------------------------------------|-----|--|
| Nominal Dimensions<br>W x H x D<br>(Inch)                                 | Actual Dimensions<br>W x H x D<br>(mm) | Filter<br>Block<br>(V) | Flange<br>(None / Single) | Rated<br>Airflow<br>(m³/h) | Face<br>Velocity<br>(m/s) | Rated Initial Pressure Drop<br>(Pa) |     | Recommended<br>Final Pressure Drop<br>(Pa) |
|   |  |                        |                           |                            |                           | H13                                 | H14 |  |
| 12 x 24 x 12  | 287 x 592 x 292                        | 2                      | Single flange             | 1,000                      | 2                         | 249                                 | 270 | 500  |
| 24 x 12 x 12  | 592 x 287 x 292                        | 4                      |                           | 1,000                      | 2                         | 249                                 | 270 | 500  |
| 24 x 20 x 12  | 592 x 490 x 292                        | 4                      |                           | 1,800                      | 2                         | 249                                 | 270 | 500  |
| 24 x 24 x 12  | 592 x 592 x 292                        | 4                      |                           | 2,200                      | 2                         | 249                                 | 270 | 500  |
| 12 x 24 x 1 2   | 305 x 610 x 292                        | 2                      | None flange               | 1,200                      | 2                         | 249                                 | 270 | 500  |
| 24 x 24 x 12  | 610 x 610 x 292                        | 4                      |                           | 2,400                      | 2                         | 249                                 | 270 | 500  |

| Product Specifications : HEPA Mini Pleated Filter-High Airflow Series |  |                        |                           |                            |                           |                                     |     |  |
|---|--|------------------------|---------------------------|----------------------------|---------------------------|-------------------------------------|-----|--|
| Nominal Dimensions<br>W x H x D<br>(Inch)                             | Actual Dimensions<br>W x H x D<br>(mm) | Filter<br>Block<br>(V) | Flange<br>(None / Single) | Rated<br>Airflow<br>(m³/h) | Face<br>Velocity<br>(m/s) | Rated Initial Pressure Drop<br>(Pa) |     | Recommended<br>Final Pressure Drop<br>(Pa) |
|   |  |                        |                           |                            |                           | H13                                 | H14 |  |
| 12 x 24 x 12  | 287 x 592 x 292                        | 2                      | Single flange             | 1,200                      | 2.5                       | 249                                 | 270 | 500  |
| 24 x 12 x 12  | 592 x 287 x 292                        | 4                      |                           | 1,200                      | 2.5                       | 249                                 | 270 | 500  |
| 24 x 20 x 12  | 592 x 490 x 292                        | 4                      |                           | 2,200                      | 2.5                       | 249                                 | 270 | 500  |
| 24 x 24 x 12  | 592 x 592 x 292                        | 4                      |                           | 2,700                      | 2.5                       | 249                                 | 270 | 500  |
| 12 x 24 x 1 2   | 305 x 610 x 292                        | 2                      | None flange               | 1,400                      | 2.5                       | 249                                 | 270 | 500  |
| 24 x 24 x 12  | 610 x 610 x 292                        | 4                      |                           | 3,000                      | 2.5                       | 249                                 | 270 | 500  |

Note: Performance initial pressure drop tolerance is ±10%.

# M-HII GEL SEALED (PAO) HIGH EFFICIENCY MINI-PLEATED FILTER (PAO GEL SEALED TYPE)

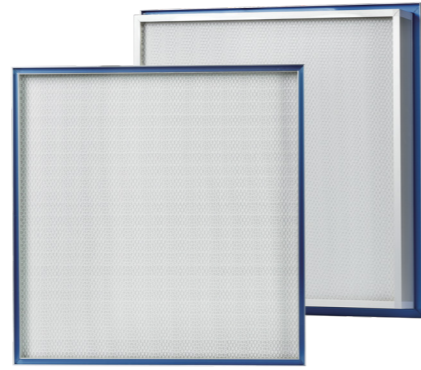

## PRODUCT FEATURES

- Partitionless design reduces operational costs
- Wide application range with compact structure to optimize storage
- Ultra-thin profile saves installation space
- Liquid tank seal design ensures superior airtightness

## APPLICATIONS

- High-efficiency air supply outlets for pharmaceutical cleanrooms, used inside laminar flow hoods
- HEPA filters paired with FFU units for cleanroom environments
- Commonly used in GMP-compliant Grade A pharmaceutical clean areas

## PRODUCT STRUCTURE DESCRIPTION

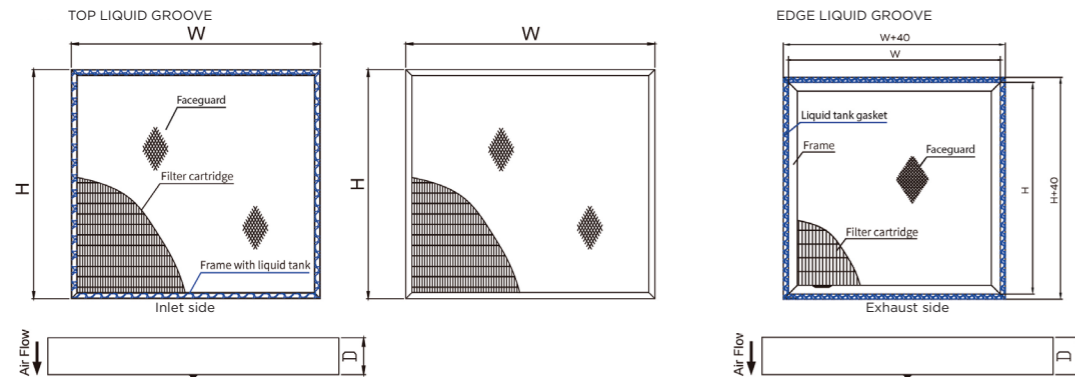

| Materials Table |   |
|-----------------|---|
| Frame           | Anodizing of aluminum profiles  |
| Thickness       | 80mm / 95mm / 100mm (top liquid tank), 90mm / 93mm (side liquid tank) |
| Filter Material | Ultrafine glass fiber   |
| Separator       | Hot melt adhesive   |
| Gasket          | Polyurethane  |
| Faceguard       | Spray-coated steel mesh   |

| Applicable Conditions |              |
|-----------------------|--------------|
| Maximum Temperature   | 70°C (158°F) |

## EFFICIENCY

- 99.995%@MPPS(H14)

## NAME SPECIFICATION

□□ - 01 - □□□ - □□□ - □□ - G□ - E□ - U

- 1 Liquid tank seal: U1-Inlet side liquid tank, U3-Outlet side liquid tank, U2-Flange folding liquid tank (93 thickness)
- 2 Airtight gasket: E0-None, E1-Inlet side, E2-Double-sided, E3-Outlet side (nitrile rubber), EP1-Inlet side, EP2-Double-sided, EP3-Outlet side (pharmaceutical industry EPDM material)
- 3 Faceguard: G0-None, G1-Outlet side, G2-Double-sided
- 4 Frame material: A-Aluminum (aluminum profile)
- 5 Dimensions: Width x Height x Thickness (WxHxD), unit: mm
- 6 Efficiency: H14
- 7 Manufacturer: MayAir
- 8 Type: HII-High efficiency mini-pleated filter (PAO gel sealed type)

## INITIAL PRESSURE DROP VS. AIRFLOW

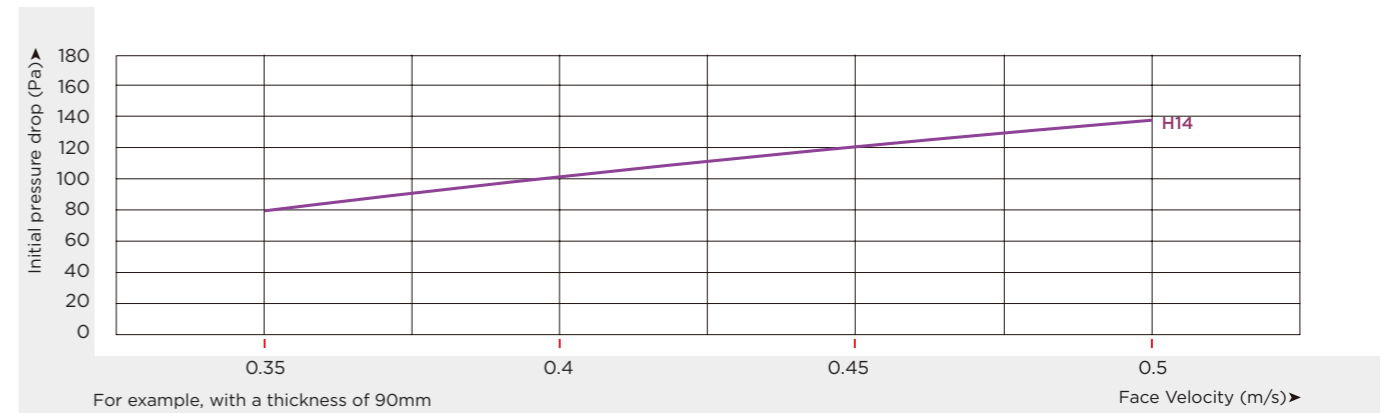

| Product Specifications - Top Liquid Tank  |                                    |                        |              |                         |                        |                                     |
|---|------------------------------------|------------------------|--------------|-------------------------|------------------------|-------------------------------------|
| Nominal Dimensions<br>W x H x D<br>(Inch) | Actual Dimensions<br>W x H<br>(mm) | Thickness<br>D<br>(mm) | Faceguard    | Rated Airflow<br>(m³/h) | Face Velocity<br>(m/s) | Rated Initial Pressure Drop<br>(Pa) |
|   |                                    |                        |              |                         |                        | H14                                 |
| 23 x 23 x 3                               | 570 x 570                          | 80                     | Double sided | 470                     | 0.45                   | 120                                 |
| 47 x 23 x 3                               | 1170 x 570                         | 80                     |              | 1,000                   | 0.45                   | 120                                 |
| 24 x 12 x 3                               | 610 x 305                          | 80                     |              | 260                     | 0.45                   | 120                                 |
| 24 x 24 x 3                               | 610 x 610                          | 80                     |              | 550                     | 0.45                   | 120                                 |
| 30 x 24 x 3                               | 762 x 610                          | 80                     |              | 690                     | 0.45                   | 120                                 |
| 36 x 24 x 3                               | 915 x 610                          | 80                     |              | 830                     | 0.45                   | 120                                 |
| 23 x 23 x 4                               | 570 x 570                          | 100                    |              | 470                     | 0.45                   | 90                                  |
| 47 x 23 x 4                               | 1170 x 570                         | 100                    |              | 1,000                   | 0.45                   | 90                                  |
| 24 x 12 x 4                               | 610 x 305                          | 100                    |              | 260                     | 0.45                   | 90                                  |
| 24 x 24 x 4                               | 610 x 610                          | 100                    |              | 550                     | 0.45                   | 90                                  |
| 30 x 24 x 4                               | 762 x 610                          | 100                    |              | 690                     | 0.45                   | 90                                  |
| 36 x 24 x 4                               | 915 x 610                          | 100                    |              | 830                     | 0.45                   | 90                                  |

| Product Specifications - Side Liquid Tank |                                      |                                |                        |              |                         |                        |                                     |
|---|--------------------------------------|--------------------------------|------------------------|--------------|-------------------------|------------------------|-------------------------------------|
| Nominal Dimensions<br>W x H x D<br>(Inch) | Internal Dimensions<br>W x H<br>(mm) | External Dimensions<br>W1 x H1 | Thickness<br>D<br>(mm) | Faceguard    | Rated Airflow<br>(m³/h) | Face Velocity<br>(m/s) | Rated Initial Pressure Drop<br>(Pa) |
|   |                                      |                                |                        |              |                         |                        | H14                                 |
| 23 x 23 x 4                               | 570 x 570                            | 599 x 266 / 610 x 610          | 90 / 93                | Double sided | 470                     | 0.45                   | 90                                  |
| 48 x 23 x 4                               | 1170 x 570                           | 1199 x 599 / 1210 x 610        | 90 / 93                |              | 1,000                   | 0.45                   | 90                                  |
| 24 x 12 x 4                               | 610 x 305                            | 639 x 334 / 650 x 345          | 90 / 93                |              | 260                     | 0.45                   | 90                                  |
| 24 x 24 x 4                               | 610 x 610                            | 639 x 639 / 650 x 650          | 90 / 93                |              | 550                     | 0.45                   | 90                                  |
| 30 x 24 x 4                               | 762 x 610                            | 791 x 639 / 802 x 650          | 90 / 93                |              | 690                     | 0.45                   | 90                                  |
| 36 x 24 x 4                               | 915 x 610                            | 944 x 639 / 955 x 650          | 90 / 93                |              | 830                     | 0.45                   | 90                                  |

Remark:  
1. Performance initial pressure drop tolerance is ±10%  
2. Custom sizes are available upon request

# M-HII/ M-UII (PAO TEST) HIGH/ ULTRA EFFICIENCY MINI-PLEATED FILTER (PAO TEST)



## PRODUCT FEATURES

- Baffle-free design reduces operating costs
- Wide range of applications with a compact structure, saving storage space
- Ultra-thin profile for space-saving installation

## APPLICATIONS

- High-efficiency air supply outlets for pharmaceutical cleanrooms
- Localized purification equipment such as laminar flow hoods, clean benches, biosafety cabinets, and transfer windows
- Compatible with FFU units in cleanroom purification environments

## EFFICIENCY

- 99.995% @ MPPS (H14)
- 99.9995% @ MPPS (U15)

## PRODUCT STRUCTURE DESCRIPTION

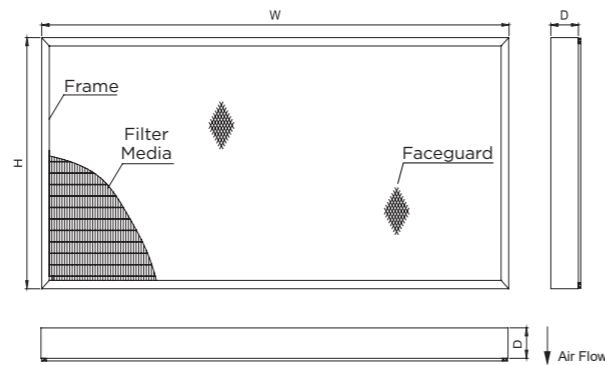

| Materials Table |                            |
|-----------------|----------------------------|
| Frame           | Anodized aluminum profile  |
| Thickness       | 50mm / 70mm / 90mm / 110mm |
| Filter Material | Ultrafine glass fiber      |
| Separator       | Hot melt adhesive          |
| Gasket          | Polyurethane               |
| Faceguard       | Spray plastic steel mesh   |

| Applicable Conditions |              |
|-----------------------|--------------|
| Maximum Temperature   | 70°C (158°F) |

## NAME SPECIFICATION

□□ - 01 - □□□ - □□□ - □□ - G□ - E□

- 1 Sealing gasket: E0-None, E1-Inlet side, E2-Double-sided, E3-Outlet side (chloroprene rubber), EP1-Inlet side, EP2-Double-sided, EP3-Outlet side (EPDM material for pharmaceutical industry)
- 2 Faceguard: G0-none, G1-outlet side, G2-double-sided
- 3 Frame material: A-Aluminum
- 4 Dimensions: Width x Height x Thickness (WxHxD), in mm
- 5 Efficiency: 99.995% @ MPPS (H14), 99.9995% @ MPPS (U15)
- 6 Manufacturer: MayAir
- 7 Type: HII-High efficiency mini-pleated filter , UII-Ultra efficiency mini-pleated filter (PAO test)

## INITIAL PRESSURE DROP VS. AIRFLOW VELOCITY

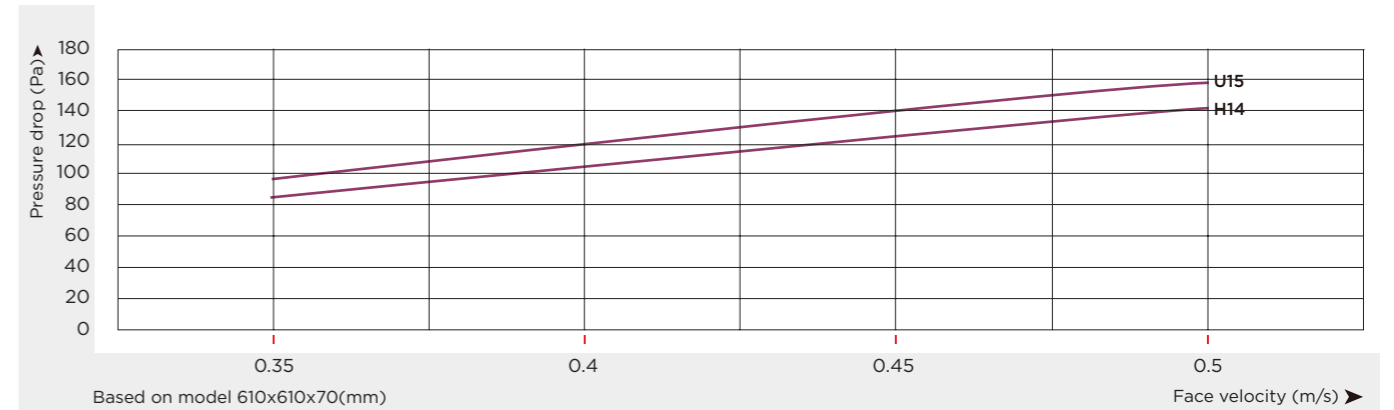

| Product Specifications                    |   |              |                   |                        |                             |     |
|---|---|--------------|-------------------|------------------------|-----------------------------|-----|
| Nominal Dimensions<br>W x H x D<br>(Inch) | Actual Dimensions<br>W x H x D<br>(mm)    | Faceguard    | Airflow<br>(m³/h) | Face Velocity<br>(m/s) | Rated Pressure Drop<br>(Pa) |     |
|   |   |              |                   |                        | H14                         | U15 |
| 23 x 23 x 1                               | 570 x 570 x 50                            | Double sided | 370               | 0.35                   | 135                         | 148 |
| 47 x 23 x 1                               | 1170 x 570 x 50                           |              | 780               | 0.35                   | 135                         | 148 |
| 24 x 12 x 1                               | 610 x 305 x 50                            |              | 200               | 0.35                   | 135                         | 148 |
| 24 x 24 x 1                               | 610 x 610 x 50                            |              | 420               | 0.35                   | 135                         | 148 |
| 30 x 24 x 1                               | 762 x 610 x 50                            |              | 540               | 0.35                   | 135                         | 148 |
| 36 x 24 x 1                               | 915 x 610 x 50                            |              | 650               | 0.35                   | 135                         | 148 |
| 47 x 35 x 1                               | 1170 x 870 x 50                           |              | 1,200             | 0.35                   | 135                         | 148 |
| 47 x 47 x 1                               | 1170 x 1170 x 50 (with reinforcement rib) |              | 1,640             | 0.35                   | 135                         | 148 |
| 23 x 23 x 2.8                             | 570 x 570 x 70                            |              | 470               | 0.45                   | 120                         | 140 |
| 47 x 23 x 2.8                             | 1170 x 570 x 70                           |              | 1,000             | 0.45                   | 120                         | 140 |
| 24 x 12 x 2.8                             | 610 x 305 x 70                            |              | 260               | 0.45                   | 120                         | 140 |
| 24 x 24 x 2.8                             | 610 x 610 x 70                            |              | 550               | 0.45                   | 120                         | 140 |
| 30 x 24 x 2.8                             | 762 x 610 x 70                            |              | 690               | 0.45                   | 120                         | 140 |
| 36 x 24 x 2.8                             | 915 x 610 x 70                            |              | 830               | 0.45                   | 120                         | 140 |
| 47 x 35 x 2.8                             | 1170 x 870 x 70                           |              | 1,550             | 0.45                   | 120                         | 140 |
| 47 x 47 x 2.8                             | 1170 x 1170 x 70                          |              | 2,100             | 0.45                   | 120                         | 140 |
| 23 x 23 x 4                               | 570 x 570 x 90                            |              | 470               | 0.45                   | 90                          | 110 |
| 47 x 23 x 4                               | 1170 x 570 x 90                           |              | 1,000             | 0.45                   | 90                          | 110 |
| 24 x 12 x 4                               | 610 x 305 x 90                            |              | 260               | 0.45                   | 90                          | 110 |
| 24 x 24 x 4                               | 610 x 610 x 90                            |              | 550               | 0.45                   | 90                          | 110 |
| 30 x 24 x 4                               | 762 x 610 x 90                            | 690          | 0.45              | 90                     | 110                         |     |
| 36 x 24 x 4                               | 915 x 610 x 90                            | 830          | 0.45              | 90                     | 110                         |     |
| 47 x 35 x 4                               | 1170 x 870 x 90                           | 1,550        | 0.45              | 90                     | 110                         |     |
| 47 x 47 x 4                               | 1170 x 1170 x 90                          | 2,100        | 0.45              | 90                     | 110                         |     |
| 23 x 23 x 5                               | 570 x 570 x 110                           | 470          | 0.45              | 70                     | 85                          |     |
| 47 x 23 x 5                               | 1170 x 570 x 110                          | 1,000        | 0.45              | 70                     | 85                          |     |
| 24 x 12 x 5                               | 610 x 305 x 110                           | 260          | 0.45              | 70                     | 85                          |     |
| 24 x 24 x 5                               | 610 x 610 x 110                           | 550          | 0.45              | 70                     | 85                          |     |
| 30 x 24 x 5                               | 762 x 610 x 110                           | 690          | 0.45              | 70                     | 85                          |     |
| 36 x 24 x 5                               | 915 x 610 x 110                           | 830          | 0.45              | 70                     | 85                          |     |
| 47 x 35 x 5                               | 1170 x 870 x 110                          | 1,550        | 0.45              | 70                     | 85                          |     |
| 47 x 47 x 5                               | 1170 x 1170 x 110                         | 2,100        | 0.45              | 70                     | 85                          |     |

Remark:  
1. Performance initial pressure drop tolerance is ±10%  
2. Custom sizes are available upon request

# M-MIH

## MEDIUM EFFICIENCY SECONDARY FILTER WITH SEPARATOR (HIGH TEMPERATURE RESISTANCE)



### PRODUCT FEATURES

- Aluminum partitions with frame options: non-flanged, single-flanged, and double-flanged, with a flange thickness of 20 mm
- Utilizes ultra-fine fiberglass filter media
- Engineered for high-temperature resistance up to 250°C (482°F)
- High-quality imported sealing adhesive ensures consistent performance

### APPLICATIONS

- Primarily used in high-temperature sterilization tunnels, ultra-clean ovens, and pharmaceutical industry environments
- Suitable for chemical, food and beverage industries, and other high-temperature air purification systems
- Ideal as secondary filters in automotive paint booth workshops
- Excellent for fire protection or ventilation systems exposed to high temperatures

### EFFICIENCY

- M6, F7, F8, F9

### PRODUCT STRUCTURE DESCRIPTION

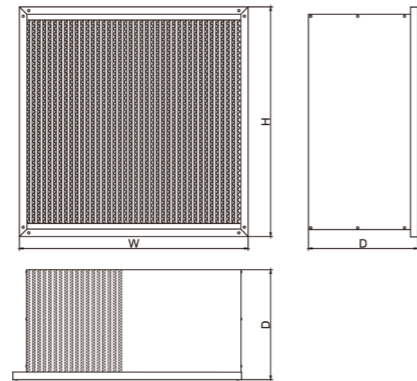

| Materials Table             |   |
|-----------------------------|---|
| Frame                       | Galvanized steel / Aluminum / Stainless steel sheet |
| Thickness                   | 80mm / 150mm / 220mm / 292mm                        |
| Filter Material             | Water-resistant fiberglass                          |
| Separator                   | Aluminum foil                                       |
| Gasket                      | High-temperature resistant sealing glue             |
| Material of Sealing Gaskets | High-temperature resistant sealing gaskets          |

High-temperature-resistant partitions are equipped with protective mesh, available in stainless steel, galvanized steel or aluminum mesh.

| Applicable Conditions |               |
|-----------------------|---------------|
| Maximum Temperature   | 250°C (482°F) |

### NAME SPECIFICATION

MIH - □□ - □□□ - □□□ - □□ - E□ - □□ - □ - □ - □

- Temperature type: 250°C, customer-requested temperature
- Design: P-Red silicone sealant
- Airflow type: N-Standard airflow, H-High airflow, HL-High airflow low-pressure drop
- Flange type: X-Non flange, D1-Single flange, D2-Double flange
- Air-tight gasket: E0-None, E1-Inlet side, E2-Both sides, E3-Outlet side
- Frame material: SS-SUS304 (Stainless steel sheet), S-SUS430 (stainless steel sheet), SG (galvanized sheet), AL-Aluminum (aluminum sheet)
- Dimensions: Width x Height x Depth (WxHxD), unit: mm
- Efficiency: M6, F7, F8, F9
- O1: MayAir brand, 15: MayAir brand for the coating industry
- Type: Medium efficiency Secondary filter with separator (high temperature resistance)

Product Specifications: High Temperature Resistance Medium Efficiency Secondary Filter with Separator - Standard Airflow

| Nominal Dimensions<br>W x H x D<br>(Inch) | Actual Dimensions<br>W x H x D<br>(mm) | Separator | Flange | Rated Airflow<br>(m³/h) | Face Velocity<br>(m/s) | Rated Initial Pressure Drop<br>(Pa) |     |     |     | Recommended Final Pressure Drop<br>(Pa) |
|---|--|-----------|--------|-------------------------|------------------------|-------------------------------------|-----|-----|-----|---|
|   |  |           |        |                         |                        | M6                                  | F7  | F8  | F9  |   |
| 12 x 24 x 3                               | 305 x 610 x 80                         | Aluminum  | None   | 400                     | 0.6                    | 90                                  | 130 | 140 | 150 | 300                                     |
| 24 x 24 x 3                               | 610 x 610 x 80                         |           |        | 800                     | 0.6                    | 90                                  | 130 | 140 | 150 | 300                                     |
| 12 x 24 x 6                               | 305 x 610 x 150                        |           |        | 850                     | 1.2                    | 90                                  | 130 | 140 | 150 | 300                                     |
| 24 x 24 x 6                               | 610 x 610 x 150                        |           |        | 1,700                   | 1.2                    | 90                                  | 130 | 140 | 150 | 300                                     |
| 12 x 24 x 9                               | 305 x 610 x 220                        |           |        | 1,080                   | 1.6                    | 90                                  | 130 | 140 | 150 | 300                                     |
| 24 x 24 x 9                               | 610 x 610 x 220                        |           |        | 2,160                   | 1.6                    | 90                                  | 130 | 140 | 150 | 300                                     |
| 12 x 24 x 12                              | 305 x 610 x 292                        |           |        | 1,700                   | 2.5                    | 90                                  | 130 | 140 | 150 | 300                                     |
| 24 x 24 x 12                              | 610 x 610 x 292                        |           |        | 3,400                   | 2.5                    | 90                                  | 130 | 140 | 150 | 300                                     |

- Remark:
- Initial pressure drop performance tolerance is ±10%.
  - Special dimensions available upon request.

# M-HIH

## HIGH-EFFICIENCY HEPA FILTER WITH SEPARATOR (HIGH TEMPERATURE RESISTANCE)



### PRODUCT FEATURES

- Aluminum partitions with frame options: non-flanged, single-flanged, and double-flanged, with a flange thickness of 20 mm
- Utilizes ultra-fine fiberglass filter media
- Engineered for high-temperature resistance up to 250°C (482°F)
- High-quality imported sealing adhesive ensures consistent performance

### APPLICATIONS

- Primarily used in high-temperature sterilization tunnels, ultra-clean ovens, and pharmaceutical industry environments
- Suitable for chemical, food and beverage industries, and other high-temperature air purification systems
- Ideal as secondary filters in automotive paint booth workshops
- Excellent for fire protection or ventilation systems exposed to high temperatures

### EFFICIENCY

- 99.95%@MPPS(H13), 99.995%@MPPS(H14)

### PRODUCT STRUCTURE DESCRIPTION

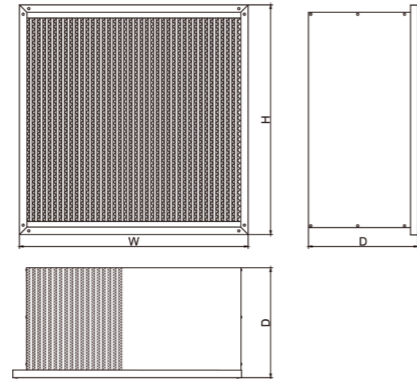

| Materials Table             |   |
|-----------------------------|---|
| Frame                       | Galvanized steel / Aluminum / Stainless steel sheet |
| Thickness                   | 80mm / 150mm / 220mm / 292mm                        |
| Filter Material             | Water-resistant fiberglass                          |
| Separator                   | Aluminum foil                                       |
| Gasket                      | High-temperature resistant sealing glue             |
| Material of Sealing Gaskets | High-temperature resistant sealing gaskets          |

High-temperature-resistant partitions are equipped with protective mesh, available in stainless steel, galvanized steel or aluminum mesh.

| Applicable Conditions |               |
|-----------------------|---------------|
| Maximum Temperature   | 250°C (482°F) |

### NAME SPECIFICATION

HIH - □□ - □□□ - □□□ - □□ - E□ - □□ - □□ - □□

- Temperature type: 250°C, customer-requested temperature
- Design: P-Red silicone sealant
- Airflow type: N-Standard airflow, H-High airflow, HL-High airflow low-pressure drop
- Flange type: X-Non flange, D1-Single flange, D2-Double flange
- Air-tight gasket: E0-None, E1-Inlet side, E2-Both sides, E3-Outlet side
- Frame material: SS-SUS304 (stainless steel sheet), S-SUS430 (stainless steel sheet), SG (galvanized sheet), AL-Aluminum (aluminum sheet)
- Dimensions: Width x Height x Depth (WxHxD), unit: mm
- Efficiency: H13, H14
- O1: MayAir brand, 15: MayAir brand for the coating industry
- Type: High-efficiency HEPA filter with separator (high temperature resistance)

### INITIAL PRESSURE DROP VS. AIRFLOW

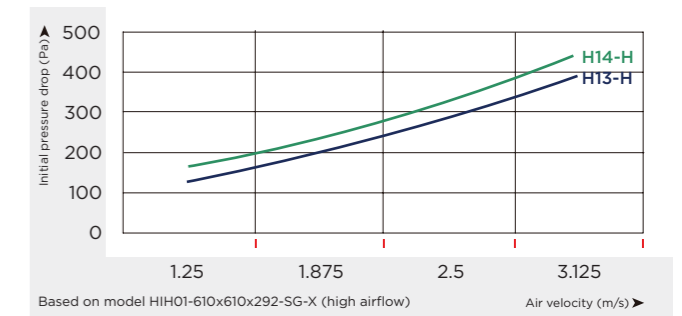
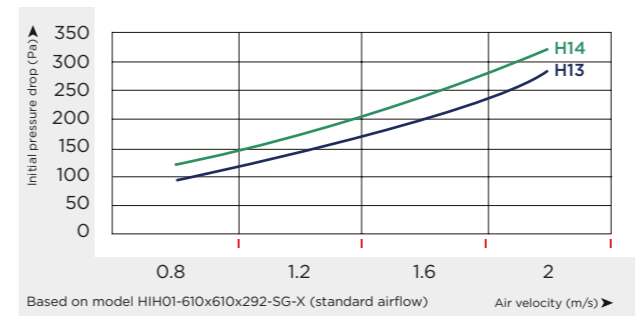

| Product Specifications: High Temperature Resistance HEPA Filter with Separator - Standard Airflow |  |           |        |                         |                        |                                     |     |   |
|---|--|-----------|--------|-------------------------|------------------------|-------------------------------------|-----|---|
| Nominal Dimensions<br>W x H x D<br>(Inch)   | Actual Dimensions<br>W x H x D<br>(mm) | Separator | Flange | Rated Airflow<br>(m³/h) | Face Velocity<br>(m/s) | Rated Initial Pressure Drop<br>(Pa) |     | Recommended Final Pressure Drop<br>(Pa) |
|   |  |           |        |                         |                        | H13                                 | H14 |   |
| 12 x 24 x 3   | 305 x 610 x 80                         | Aluminum  | None   | 200                     | 0.36                   | 249                                 | 280 | Initial Pressure Drop<br>2 to 2.5 times |
| 24 x 24 x 3   | 610 x 610 x 80                         |           |        | 420                     | 0.36                   | 249                                 | 280 |   |
| 12 x 24 x 6   | 305 x 610 x 150                        |           |        | 420                     | 0.77                   | 249                                 | 280 |   |
| 24 x 24 x 6   | 610 x 610 x 150                        |           |        | 900                     | 0.77                   | 249                                 | 280 |   |
| 12 x 24 x 9   | 305 x 610 x 220                        |           |        | 650                     | 1.20                   | 249                                 | 280 |   |
| 24 x 24 x 9   | 610 x 610 x 220                        |           |        | 1,400                   | 1.20                   | 249                                 | 280 |   |
| 12 x 24 x 12  | 305 x 610 x 292                        |           |        | 860                     | 1.60                   | 249                                 | 280 |   |
| 12 x 24 x 12  | 610 x 610 x 292                        |           |        | 1,860                   | 1.60                   | 249                                 | 280 |   |

| Product Specifications: High Temperature Resistance HEPA Filter with Separator - High Airflow |  |           |        |                         |                        |                                     |     |   |
|---|--|-----------|--------|-------------------------|------------------------|-------------------------------------|-----|---|
| Nominal Dimensions<br>W x H x D<br>(Inch)   | Actual Dimensions<br>W x H x D<br>(mm) | Separator | Flange | Rated Airflow<br>(m³/h) | Face Velocity<br>(m/s) | Rated Initial Pressure Drop<br>(Pa) |     | Recommended Final Pressure Drop<br>(Pa) |
|   |  |           |        |                         |                        | H13                                 | H14 |   |
| 12 x 24 x 6   | 305 x 610 x 150                        | Aluminum  | None   | 550                     | 1.00                   | 249                                 | 280 | Initial Pressure Drop<br>2 to 2.5 times |
| 24 x 24 x 6   | 610 x 610 x 150                        |           |        | 1,170                   | 1.00                   | 249                                 | 280 |   |
| 12 x 24 x 9   | 305 x 610 x 220                        |           |        | 850                     | 1.55                   | 249                                 | 280 |   |
| 24 x 24 x 9   | 610 x 610 x 220                        |           |        | 1,820                   | 1.55                   | 249                                 | 280 |   |
| 12 x 24 x 12  | 305 x 610 x 292                        |           |        | 1,120                   | 2.00                   | 249                                 | 280 |   |
| 12 x 24 x 12  | 610 x 610 x 292                        |           |        | 2,400                   | 2.00                   | 249                                 | 280 |   |

| Product Specifications: High Temperature Resistance HEPA Filter with Separator - High Airflow Low Pressure Drop |  |           |        |                         |                        |                                     |     |   |
|---|--|-----------|--------|-------------------------|------------------------|-------------------------------------|-----|---|
| Nominal Dimensions<br>W x H x D<br>(Inch)   | Actual Dimensions<br>W x H x D<br>(mm) | Separator | Flange | Rated Airflow<br>(m³/h) | Face Velocity<br>(m/s) | Rated Initial Pressure Drop<br>(Pa) |     | Recommended Final Pressure Drop<br>(Pa) |
|   |  |           |        |                         |                        | H13                                 | H14 |   |
| 12 x 24 x 12  | 305 x 610 x 292                        | Aluminum  | None   | 1,400                   | 2.50                   | 330                                 | 380 | Initial Pressure Drop<br>2 to 2.5 times |
| 24 x 24 x 12  | 610 x 610 x 292                        |           |        | 3,000                   | 2.50                   | 330                                 | 380 |   |

Remark:  
1. All initial pressure drop performance values listed above have a tolerance of ±10%.  
2. Special dimensions available upon request

# M-HIH

## 350°C HIGH-EFFICIENCY HEPA FILTER WITH SEPARATOR (HIGH TEMPERATURE RESISTANCE)

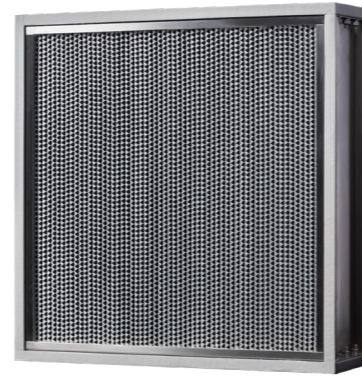

### PRODUCT FEATURES

- Aluminum separators with frame available in double-flanged design
- Constructed with imported ultra-fine glass fiber media
- Ceramic sealant ensures stable and reliable performance under high temperatures

### APPLICATIONS

- Primarily used in high-temperature air purification systems and equipment such as automotive paint spray booths, pharmaceutical sterilization tunnels, and ultra-clean ovens
- Suitable for ventilation systems requiring high fire safety standards or operating under elevated airflow temperatures

### EFFICIENCY

- 99.95%@MPPS(H13)

### PRODUCT STRUCTURE DESCRIPTION

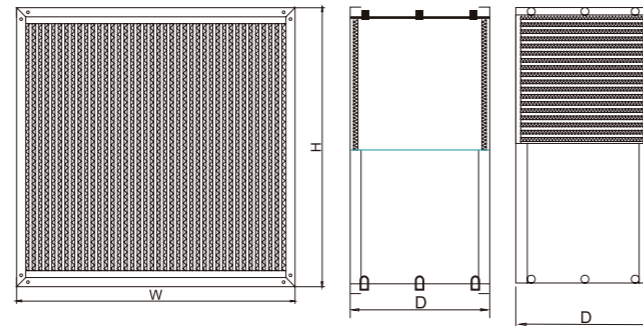

| Materials Table             |  |
|-----------------------------|--|
| Frame                       | SUS 304 Stainless Steel (HEPA H13 Grade) |
| Thickness                   | 150mm / 292mm                            |
| Filter Material             | Ultrafine glass fiber                    |
| Separator                   | Aluminum foil                            |
| Gasket                      | Ceramic                                  |
| Material of Sealing Gaskets | Glass Fiber                              |
| Applicable Conditions       |  |
| Maximum Temperature         | 350°C (662°F)                            |

### NAME SPECIFICATION

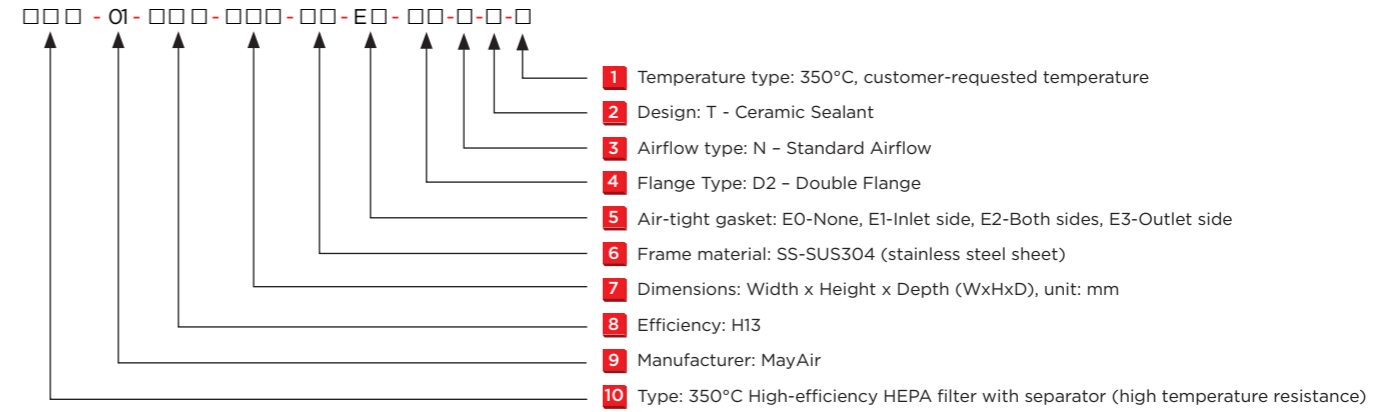

### INITIAL PRESSURE DROP VS. AIRFLOW VELOCITY

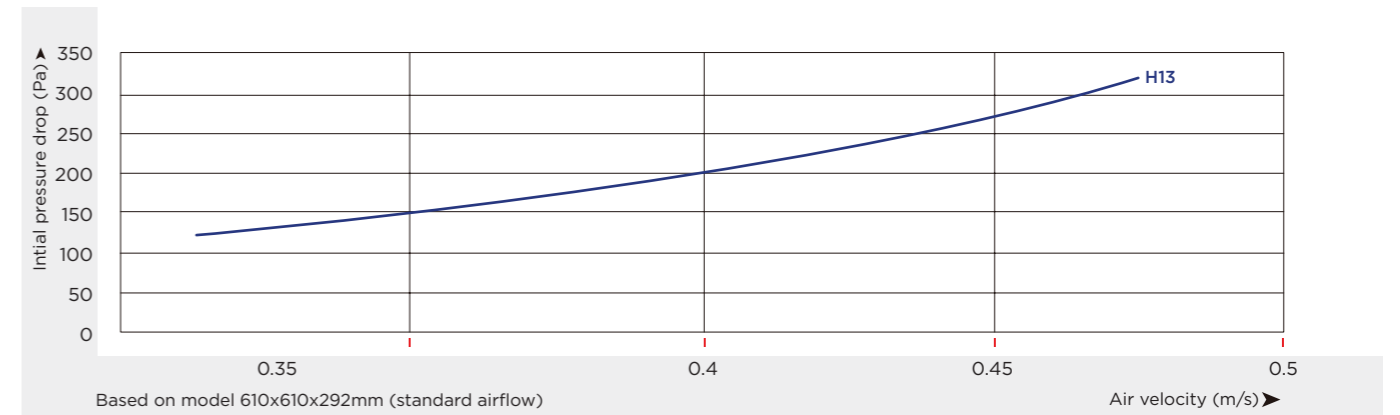

| Product Specifications                    |  |           |        |                                      |                        |             |                                  |   |
|---|--|-----------|--------|--------------------------------------|------------------------|-------------|----------------------------------|---|
| Nominal Dimensions<br>W x H x D<br>(Inch) | Actual Dimensions<br>W x H x D<br>(mm) | Separator | Flange | Rated Airflow<br>(m <sup>3</sup> /h) | Face Velocity<br>(m/s) | Efficiency  | Rated Initial Pressure Drop (Pa) | Recommended Final Pressure Drop (Pa)    |
|   |  |           |        |                                      |                        |             | H13                              |   |
| 12 x 12 x 6                               | 305 x 305 x 150                        | Aluminum  | None   | 230                                  | 0.9                    | 99.95%@MPPS | 249                              | Initial Pressure Drop<br>2 to 2.5 times |
| 12 x 24 x 6                               | 305 x 610 x 150                        |           |        | 510                                  | 0.9                    |             | 249                              |   |
| 24 x 24 x 6                               | 610 x 610 x 150                        |           |        | 1,080                                | 0.9                    |             | 249                              |   |
| 30 x 24 x 6                               | 762 x 610 x 150                        |           |        | 1,320                                | 0.9                    |             | 249                              |   |
| 12 x 12 x 12                              | 305 x 305 x 292                        |           |        | 380                                  | 1.6                    |             | 249                              |   |
| 12 x 24 x 12                              | 305 x 610 x 292                        |           |        | 900                                  | 1.6                    |             | 249                              |   |
| 24 x 24 x 12                              | 610 x 610 x 292                        |           |        | 1,900                                | 1.6                    |             | 249                              |   |
| 30 x 24 x 12                              | 762 x 610 x 292                        |           |        | 2,400                                | 1.6                    |             | 249                              |   |

Note: The initial pressure drop performance tolerance is ±10%.

# M-PBOX

## REPLACEABLE HIGH EFFICIENCY HEPA TERMINAL UNIT



### PRODUCT FEATURES

- Replaceable filter-cartridge design
- Three sealing options: mechanical seal, liquid tank seal, and double seal for enhanced sealing performance
- Compliant with on-site PAO testing requirements
- Highly versatile and adaptable for various applications

### APPLICATIONS

- Mainly used in high-temperature air purification systems and equipment, such as automotive paint spray booths, high-temperature sterilization tunnels in the pharmaceutical industry, and ultra-clean ovens

### OPTIONAL ACCESSORIES

- Outlet Face Guard 1: Full-perforated type
- Outlet Face Guard 2: Louvered type
- Outlet Face Guard 3: Swirl type
- Outlet Face Guard 4: Downward-protruding type
- PAO Test Port & Aerosol Injection Port: 8mm quick connector for air tubing
- Aerosol Ring: 10mm perforated stainless steel aerosol tube
- Top-Adjustable Air Volume Damper: Adjustable air volume from above the ceiling
- Insulation Cotton: Standard thickness 15 mm, customizable upon request

### EFFICIENCY

- H14 99.995%@MPPS

### PRODUCT STRUCTURE DESCRIPTION

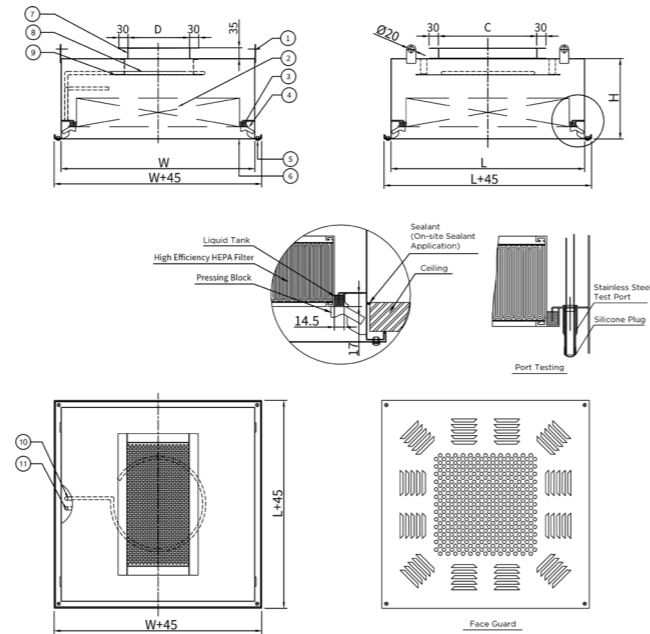

| Material Table    |  |
|-------------------|--|
| Casing            | Spray-coated cold-rolled steel plate / Stainless steel (SUS304) / Aluminum plate                                       |
| Flange            | Spray-coated cold-rolled steel plate / Stainless steel (SUS304) / Aluminum plate                                       |
| Air Diffuser      | Spray-coated cold-rolled steel plate perforated plate / Stainless steel (SUS304) / Aluminum plate                      |
| Pressure Block    | Galvanized steel plate / Stainless steel (SUS304) / ABS  |
| Faceguard         | Spray-coated aluminum plate perforated plate / Spray-coated cold-rolled steel plate / Stainless steel (SUS304)         |
| Control Valve     | Spray-coated cold-rolled steel plate / Stainless steel (SUS304)  |
| Insulation Cotton | PE (Polyethylene)  |
| Hepa Filter       | Refer to the HEPA filter specifications on page 80: 100mm thick for the top trough, 90-93mm thick for the side troughs |

| Operating Conditions |              |
|----------------------|--------------|
| Maximum Temperature  | 70°C (158°F) |

### NAME SPECIFICATION

HB - 01 - □□ - □□ - □□ - □□ - □□ - □□ - □□

- 1T: With one test port, 2T: One dust generation ring and one test port
- HP: With insulation cotton, blank: Without insulation cotton
- V1: Top adjustment, V2: Bottom adjustment, blank: Without regulating valve
- O1: Circular top-mounted, O2: Circular side-mounted, O3: Square top-mounted, O4: Square side-mounted
- Y1: Full-perforated flat face guard, Y2: Louvered flat face guard, T: Downward-protruding face guard, blank: Without face guard
- A: Inward-folded edge, B: Outward-folded edge
- S: SUS304, SP: SPCC (Cold-rolled steel with powder coating)
- 8 Dimensions: Length × Width × Height (L×W×H), unit: mm
- 9 Manufacturer: Mayair
- 10 Type: M-PBOX Replaceable HEPA terminal unit

### INITIAL PRESSURE DROP VS. AIRFLOW VELOCITY

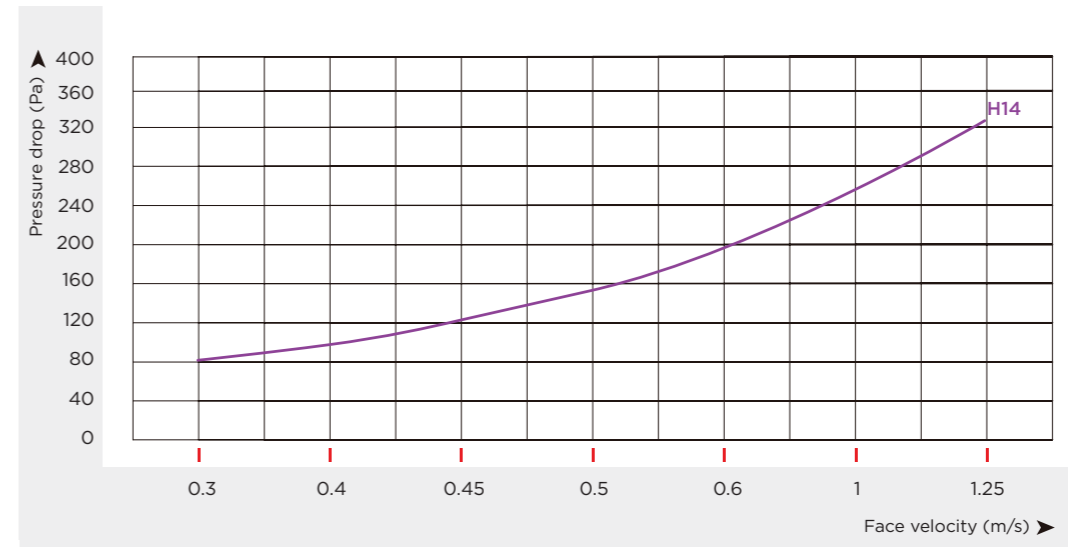

| Inlet Ring and Regulating Valve Height Table |                             |                                     |
|--|-----------------------------|-------------------------------------|
| Air Outlet Diameter                          | Standard Height of Air Ring | Standard Height of Regulating Valve |
| Ø250   | 60                          | 230                                 |
| Ø300   | 60                          | 280                                 |
| Ø350   | 60                          | 330                                 |
| Ø450   | 60                          | 430                                 |

| Product Specifications   |                                  |  |  |                  |                               |   |                                      |
|--------------------------|----------------------------------|--|--|------------------|-------------------------------|---|--------------------------------------|
|                          | Filter Size<br>W x H x D<br>(mm) | Enclosure Dimensions<br>(Top Supply Air)<br>L x W x H (mm) | Enclosure Dimensions<br>(Top Supply Air)<br>L x W x H (mm) | Airflow<br>(CMH) | Rectangular<br>Flange<br>(mm) | Circular Flange<br>(Top Supply)<br>(mm) | Initial Filter<br>Pressure Drop (Pa) |
|                          |                                  |  |  |                  |                               |   | H14 99.995%@MPPS                     |
| Edge<br>liquid<br>trough | 420 x 420 x 90                   | 480 x 480 x 260  | 480 x 480 x 430  | 500              | 200 x 200                     | Φ200                                    | 250                                  |
|                          | 570 x 570 x 90                   | 630 x 630 x 260  | 630 x 630 x 430  | 1,000            | 320 x 200                     | Φ300                                    | 250                                  |
|                          | 670 x 670 x 90                   | 730 x 730 x 260  | 730 x 730 x 480  | 1,500            | 320 x 250                     | Φ350                                    | 250                                  |
|                          | 955 x 650 x 90                   | 1015 x 710 x 260   | 1015 x 710 x 480   | 2,000            | 400 x 250                     | Φ400                                    | 250                                  |

- Remark:
1. The side supply air type is only compatible with a rectangular interface.
  2. The dimensions listed above apply to the side-trough design with a PAO test port.
  3. The initial pressure drop performance tolerance is ±10%.

## SMART HEPA BOX SMART HEPA TERMINAL UNIT

A HEPA terminal diffuser with built-in air volume control functionality. It maintains a preset air volume via wired configuration and automatically adjusts the opening angle to compensate for increasing filter resistance, ensuring a constant airflow.



### PRODUCT FEATURES

- **Energy Saving:** Optional low-resistance, high dust-holding capacity filter with a rated resistance as low as 120 Pa, reducing overall energy consumption by 20-30%
- **Online Control:** No need for personnel to access the technical ceiling for adjustment, maintenance, or replacement
- **Digital Transmission:** Supports display and control through a computer or touchscreen interface
- **No Interference:** Utilizes a pressure-independent constant air volume device to ensure airflow of other diffusers remains unaffected
- **Mode Switching:** Allows seamless transition between production and standby modes
- **Smart Self-Regulation:** Automatically maintains constant air exchange rates and pressure differentials in controlled spaces
- **Built-in Design:** Constant air volume mechanism contains no wearable components
- **Unchanged Appearance:** Diffuser design remains unchanged with no need for additional accessories or extended ducting, simplifying system layout
- **Integrated System:** Combines actuator, controller, and diffuser into a single unit

### APPLICATIONS

- Widely used in clean air conditioning systems for industries such as pharmaceuticals, healthcare, electronics, and chemicals. Supports both constant and variable air volume control modes.

### CONTROL DESCRIPTION

- **Wired Communication:** Equipped with an RS485 communication interface, the smart diffuser can connect to a serial server, which links to an Ethernet switch. This switch connects to the backend monitoring system using the MODBUS-RTU protocol.
  1. Enables real-time monitoring of the diffuser's current opening angle, airflow, temperature, and humidity
  2. Airflow parameters can be configured as required

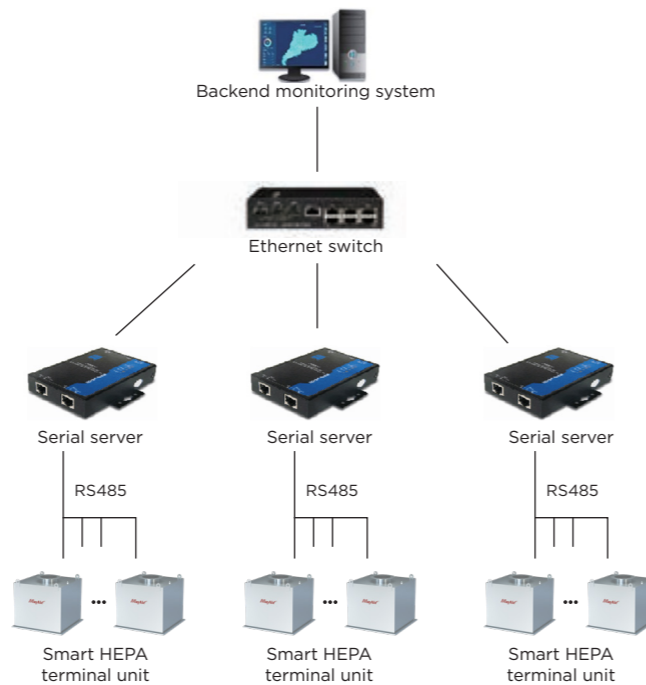

### FACE GUARD TYPE

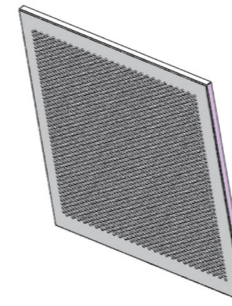

Y1 - Full-Perforated Type

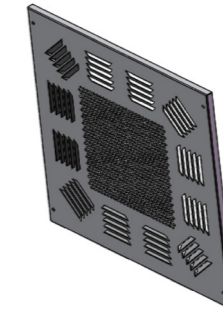

Y2 - Louvered Type

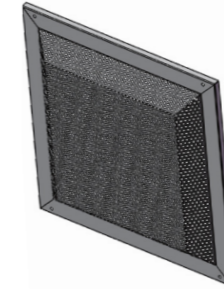

T - Downward-Protruding Type

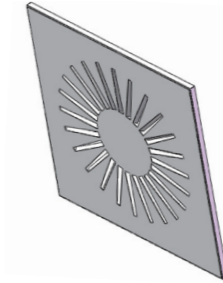

S - Swirl Type

| Product Specifications   |               |   |                        |  |  |  |
|--|---------------|---|------------------------|--|--|--|
| Smart High-Efficiency Air Diffuser (Cold-Rolled Steel / Stainless Steel) |               |   |                        |  |  |  |
| No   | Airflow (CMH) | Cabinet Dimensions (mm)<br>Top Air Supply | Filter Dimensions (mm) | Initial Pressure Drop of Filter (Pa)<br>H14 99.995% @ MPPS | Constant Air Volume Device (Diameter mm) | Duct Flange Dimensions (mm)<br>Square-to-Round Flange (Top Air Supply) |
| 1  | 500           | 480 x 480 x 430                           | 420 x 420 x 90         | ≤250   | 160                                      | 200 x 200  |
| 2  | 1,000         | 630 x 630 x 430                           | 570 x 570 x 90         | ≤250   | 250                                      | 320 x 200  |
| 3  | 1,500         | 730 x 730 x 430                           | 670 x 670 x 90         | ≤250   | 250                                      | 320 x 250  |
| 4  | 2,000         | 1015 x 710 x 450                          | 955 x 650 x 90         | ≤250   | 315                                      | 400 x 250  |

## BIOLOGICAL SAFETY CABINETS



### PRODUCT FEATURES

- Utilizes a dual-fan cabinet structure for balanced internal airflow distribution. Equipped with energy-efficient DC brushless motors for low noise, energy savings, and environmental protection
- Total unit height: 2050 mm, compatible with most standard room doorways. The cabinet and support frame are detachable for easy transportation. Features a color LED display with a touch control panel, ensuring user-friendly operation and reducing the risk of misuse. The screen displays downflow velocity, inflow velocity, filter lifespan, total runtime, clock, and various system alarms
- Includes high-precision differential pressure sensors for real-time monitoring of both downflow and inflow velocities
- Comes standard with an intelligent electric sliding glass door (manual version available)
- A 304 stainless steel liquid collection tank is installed below the work surface, complete with a standard drain valve
- Integrated ULPA ultra-high-efficiency filters, certified by CNAS, paired with a negative pressure sealing design, ensure ISO Class 1 air cleanliness within the working area
- The UV lamp scheduling function allows for pre-set on/off times. Safety interlocks prevent operation when the front door, lighting, or fan are in use

#### Excellent Airflow Pattern

- Dual-fan box design for more optimized airflow distribution
- Energy-efficient DC brushless fans
- Optimized return air duct design for efficient and smooth circulation

#### Accurate Airflow Monitoring

- Equipped with two high-precision differential pressure sensors
- Enables real-time monitoring of both downflow and inflow velocities

#### Comfortable Working Space

- 10° angled front window improves ergonomic comfort
- Larger working area within a compact overall unit design
- Lower operating noise levels
- Bright, evenly distributed illumination enhances visibility

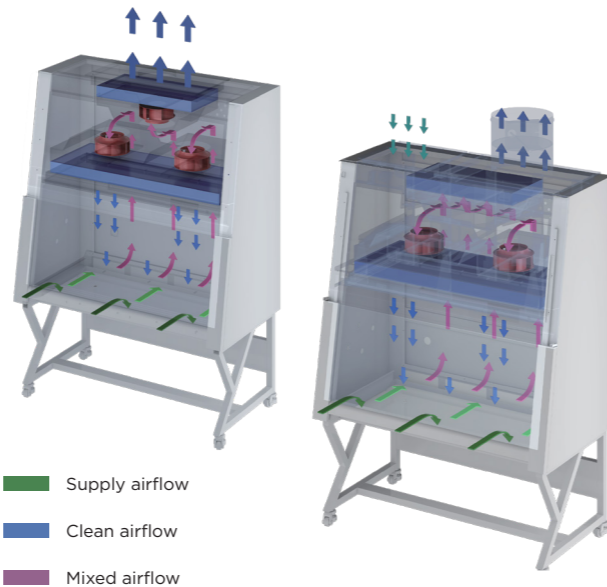

- Supply airflow
- Clean airflow
- Mixed airflow

| Product Specifications   |  |   |  |  |
|--|--|---|--|--|
| Technical Specifications of Class II Type A2 Biosafety Cabinet |  |   |  |  |
| Model  | BSC01-1000IIA2-01  | BSC01-1300IIA2-01   | BSC01-1600IIA2-01  | BSC01-1800IIA2-01  |
| Airflow Pattern  | 70% recirculated, 30% exhausted  | 70% recirculated, 30% exhausted   | 70% recirculated, 30% exhausted                          | 70% recirculated, 30% exhausted                          |
| Downflow Velocity  | 0.32±0.025m/s  | 0.32±0.025m/s   | 0.32±0.025m/s  | 0.32±0.025m/s  |
| Inflow Velocity  | 0.53±0.025m/s  | 0.53±0.025m/s   | 0.53±0.025m/s  | 0.53±0.025m/s  |
| Noise Level  | 65dB (A)   | 65dB (A)  | 65dB (A)   | 65dB (A)   |
| Vibration  | ≤5μm   | ≤5μm  | ≤5μm   | ≤5μm   |
| Illuminance  | ≥1,200lx   | ≥1,200lx  | ≥1,200lx   | ≥1,200lx   |
| Ultraviolet Radiation Intensity                                | ≥400mW/m <sup>2</sup>  | ≥400mW/m <sup>2</sup>   | ≥400mW/m <sup>2</sup>                                    | ≥400mW/m <sup>2</sup>                                    |
| Cleanliness Class Of Work Area                                 | Class 10   | Class 10  | Class 10   | Class 10   |
| Ultra-High Efficiency Air Filter                               | ≥99.9995%@0.12μm   |   |  |  |
| Biological Protection  | Personnel protection<br>Product protection<br>Cross-contamination protection | 1-8×10 <sup>4</sup> , three consecutive times, ≤10 CFU/time<br>1-8×10 <sup>4</sup> , three consecutive times, ≤5 CFU/time<br>1-8×10 <sup>4</sup> , three consecutive times, ≤2 CFU/time |  |  |
| Rated Power  | 600W   | 600W  | 600W   | 600W   |
| Power Supply   | AC220V, 50Hz   | AC220V, 50Hz  | AC220V, 50Hz   | AC220V, 50Hz   |
| Work Area Dimensions (W × D × H)                               | 1000 × 630 × 620mm   | 1300 × 630 × 620mm  | 1600 × 630 × 620mm                                       | 1800 × 630 × 620mm                                       |
| External Dimensions (W × D × H)                                | 1200 × 780 × 2050<br>(Manual sliding door depth: 795 mm)                     | 1500 × 780 × 2050<br>(Manual sliding door depth: 795 mm)  | 1800 × 780 × 2050<br>(Manual sliding door depth: 795 mm) | 2000 × 780 × 2050<br>(Manual sliding door depth: 795 mm) |
| Technical Specifications of Class II Type B2 Biosafety Cabinet |  |   |  |  |
| Model  | BSC01-1000IIB2-01  | BSC01-1300IIB2-01   | BSC01-1600IIB2-01  | BSC01-1800IIB2-01  |
| Airflow Pattern  | 100% exhaust   | 100% exhaust  | 100% exhaust   | 100% exhaust   |
| Downflow Velocity  | 0.32±0.025m/s  | 0.32±0.025m/s   | 0.32±0.025m/s  | 0.32±0.025m/s  |
| Inflow Velocity  | 0.53±0.025m/s  | 0.53±0.025m/s   | 0.53±0.025m/s  | 0.53±0.025m/s  |
| Noise Level  | 65dB (A)   | 65dB (A)  | 65dB (A)   | 65dB (A)   |
| Vibration  | ≤5μm   | ≤5μm  | ≤5μm   | ≤5μm   |
| Illuminance  | ≥1,200lx   | ≥1,200lx  | ≥1,200lx   | ≥1,200lx   |
| Ultraviolet Radiation Intensity                                | ≥400mW/m <sup>2</sup>  | ≥400mW/m <sup>2</sup>   | ≥400mW/m <sup>2</sup>                                    | ≥400mW/m <sup>2</sup>                                    |
| Cleanliness Class Of Work Area                                 | Class 10   | Class 10  | Class 10   | Class 10   |
| Ultra-High Efficiency Air Filter                               | ≥99.9995%@0.12μm   |   |  |  |
| Biological Protection  | Personnel protection<br>Product protection<br>Cross-contamination protection | 1-8×10 <sup>4</sup> , three consecutive times, ≤10 CFU/time<br>1-8×10 <sup>4</sup> , three consecutive times, ≤5 CFU/time<br>1-8×10 <sup>4</sup> , three consecutive times, ≤2 CFU/time |  |  |
| Rated Power  | 600W   | 600W  | 600W   | 600W   |
| Power Supply   | AC220V, 50Hz   | AC220V, 50Hz  | AC220V, 50Hz   | AC220V, 50Hz   |
| Work Area Dimensions (W × D × H)                               | 1000 × 630 × 620mm   | 1300 × 630 × 620mm  | 1600 × 630 × 620mm                                       | 1800 × 630 × 620mm                                       |
| External Dimensions (W × D × H)                                | 1200 × 780 × 2050<br>(Manual sliding door depth: 795 mm)                     | 1500 × 780 × 2050<br>(Manual sliding door depth: 795 mm)  | 1800 × 780 × 2050<br>(Manual sliding door depth: 795 mm) | 2000 × 780 × 2050<br>(Manual sliding door depth: 795 mm) |

## CLEAN BENCH



### PRODUCT FEATURES

- Dual-fan design ensures enhanced airflow uniformity; equipped with DC brushless motors for low noise, energy efficiency, and environmental friendliness
- Total height: 1980 mm, compatible with most standard doorways; the cabinet and stand are detachable for easy transportation
- Color LED display with touch control buttons provides intuitive operation and prevents accidental misuse; dynamically displays downflow velocity, filter lifespan, total runtime, clock, and various system alarms
- Integrated HEPA filters certified by CNAS and negative pressure sealing design ensure ISO Class 5 (Class 100) air cleanliness in the working area
- Equipped with a high-precision differential pressure sensor for real-time monitoring of downflow velocity
- UV lamp scheduling function allows for preset ON/OFF timing; interlocked with the sash, lighting, and fan for added safety
- Counterweight manual sash enables smooth one-handed operation, enhancing stability and usability

#### Excellent Uniform Airflow

- Dual-fan structure optimizes airflow distribution
- High-efficiency DC brushless fans reduce energy consumption
- Top-mounted pre-filter protects the fan and extends HEPA filter service life

#### Accurate Airflow Monitoring

- Equipped with two high-precision differential pressure sensors
- Enables real-time monitoring of both downflow and inflow velocities

#### Comfortable Working Space

- 10° angled front window improves ergonomic comfort
- Larger working area within a compact overall unit design
- Lower operating noise levels
- Bright, evenly distributed illumination enhances visibility

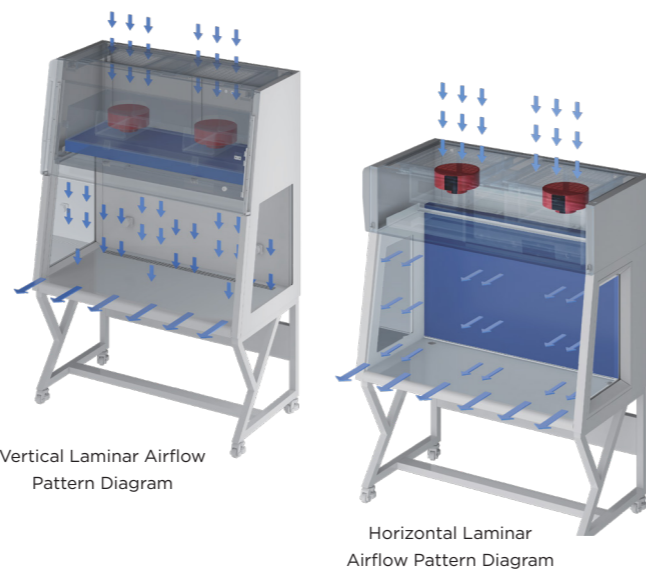

Vertical Laminar Airflow Pattern Diagram

Horizontal Laminar Airflow Pattern Diagram

| Product Specifications  |   |                       |                       |                       |
|---|---|-----------------------|-----------------------|-----------------------|
| Specifications - Advanced Vertical Laminar Flow Clean Bench   |   |                       |                       |                       |
| Model   | CB01-V1000-01                             | CB01-V1300-01         | CB01-V1600-01         | CB01-V1800-01         |
| Airflow Velocity  | 0.40±0.03m/s                              | 0.40±0.03m/s          | 0.40±0.03m/s          | 0.40±0.03m/s          |
| Settle Plate Bacterial Concentration                          | ≤0.5 CFU/plate-0.5h (φ90 mm culture dish) |                       |                       |                       |
| Cleanliness Class   | Class 100                                 | Class 100             | Class 100             | Class 100             |
| Noise Level   | 65dB (A)                                  | 65dB (A)              | 65dB (A)              | 65dB (A)              |
| Vibration   | ≤5μm                                      | ≤5μm                  | ≤5μm                  | ≤5μm                  |
| Illuminance   | ≥1,200lx                                  | ≥1,200lx              | ≥1,200lx              | ≥1,200lx              |
| Uv Radiation Intensity  | ≥400mW/m <sup>2</sup>                     | ≥400mW/m <sup>2</sup> | ≥400mW/m <sup>2</sup> | ≥400mW/m <sup>2</sup> |
| High Efficiency Air Filter                                    | ≥99.995%, @0.3um                          |                       |                       |                       |
| Rated Power   | 600W                                      | 600W                  | 600W                  | 600W                  |
| Power Supply  | AC220V, 50Hz                              | AC220V, 50Hz          | AC220V, 50Hz          | AC220V, 50Hz          |
| Work Area Dimensions (W × D × H)                              | 1000×650×650mm                            | 1300×650×650mm        | 1600×650×650mm        | 1800×650×650mm        |
| External Dimensions (W × D × H)                               | 1080×760×2000mm                           | 1380×760×2000mm       | 1680×760×2000mm       | 1880×760×2000mm       |
| Specifications - Advanced Horizontal Laminar Flow Clean Bench |   |                       |                       |                       |
| Model   | CB01-H1000-01                             | CB01-H1300-01         | CB01-H1600-01         | CB01-H1800-01         |
| Airflow Velocity  | 0.40±0.03m/s                              | 0.40±0.03m/s          | 0.40±0.03m/s          | 0.40±0.03m/s          |
| Settle Plate Bacterial Concentration                          | ≤0.5 CFU/plate-0.5h (φ90 mm culture dish) |                       |                       |                       |
| Cleanliness Class   | Class 100                                 | Class 100             | Class 100             | Class 100             |
| Noise Level   | 65dB (A)                                  | 65dB (A)              | 65dB (A)              | 65dB (A)              |
| Vibration   | ≤5μm                                      | ≤5μm                  | ≤5μm                  | ≤5μm                  |
| Illuminance   | ≥1,200lx                                  | ≥1,200lx              | ≥1,200lx              | ≥1,200lx              |
| Uv Radiation Intensity  | ≥400mW/m <sup>2</sup>                     | ≥400mW/m <sup>2</sup> | ≥400mW/m <sup>2</sup> | ≥400mW/m <sup>2</sup> |
| High Efficiency Air Filter                                    | ≥99.995%, @0.3um                          |                       |                       |                       |
| Rated Power   | 600W                                      | 600W                  | 600W                  | 600W                  |
| Power Supply  | AC220V, 50Hz                              | AC220V, 50Hz          | AC220V, 50Hz          | AC220V, 50Hz          |
| Work area dimensions (W × D × H)                              | 1000×600×720mm                            | 1300×600×720mm        | 1600×600×720mm        | 1800×600×720mm        |
| External dimensions (W × D × H)                               | 1100×790×1800mm                           | 1400×790×1800mm       | 1700×790×1800mm       | 1900×790×1800mm       |
| Specifications - Economy Vertical Laminar Flow Clean Bench    |   |                       |                       |                       |
| Model   | CB01-EV900-01                             |                       | CB01-EV1400-01        |                       |
| Airflow Velocity  | 0.40±0.03m/s                              |                       | 0.40±0.03m/s          |                       |
| Settle Plate Bacterial Concentration                          | ≤0.5 CFU/plate-0.5h (φ90 mm culture dish) |                       |                       |                       |
| Cleanliness Class   | Class 100                                 |                       | Class 100             |                       |
| Noise Level   | 65dB (A)                                  |                       | 65dB (A)              |                       |
| Vibration   | ≤5μm                                      |                       | ≤5μm                  |                       |
| Illuminance   | ≥1,200lx                                  |                       | ≥1,200lx              |                       |
| Uv Radiation Intensity  | ≥400mW/m <sup>2</sup>                     |                       | ≥400mW/m <sup>2</sup> |                       |
| High Efficiency Air Filter                                    | ≥99.995%, @0.3um                          |                       |                       |                       |
| Rated Power   | 300W                                      |                       | 600W                  |                       |
| Power Supply  | AC220V, 50Hz                              |                       | AC220V, 50Hz          |                       |
| Work Area Dimensions (W × D × H)                              | 900×690×520mm                             |                       | 1400×690×520mm        |                       |
| External Dimensions (W × D × H)                               | 1160×730×1750mm                           |                       | 1560×730×1750mm       |                       |

## Isolator Inlet Filter Cartridge



### PRODUCT DESCRIPTION

- High-efficiency filter designed for glove boxes and similar isolation equipment
- Equipped with H14-grade high-efficiency glass fiber filter media, capable of capturing fine particulate matter
- Rated air volume: 50 m<sup>3</sup>/h
- Maximum operating temperature: 70°C
- Ideal for use in glove boxes, isolators, and other controlled environments
- Effectively removes dust, bacteria, and aerosols in nuclear power and biopharmaceutical applications

### PRODUCT INSTALLATION

- **Installation Method:**  
Secure the filter by screwing it into the threaded pipe of the equipment. Ensure a tight seal for optimal filtration performance.

### AIRFLOW VS. PRESSURE DROP

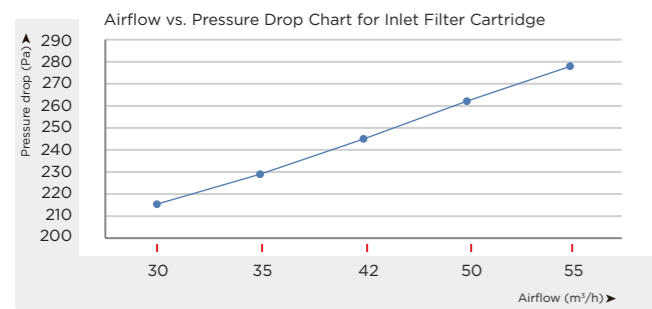

### WORKING PRINCIPLE

- Contaminated air within the isolator chamber enters the bottom of the filter cartridge, where it is filtered through the high-efficiency media.
- The purified air then flows into the next filter cartridge or system stage, and is eventually discharged from the system.

Working Principle of the Inlet Filter Cartridge

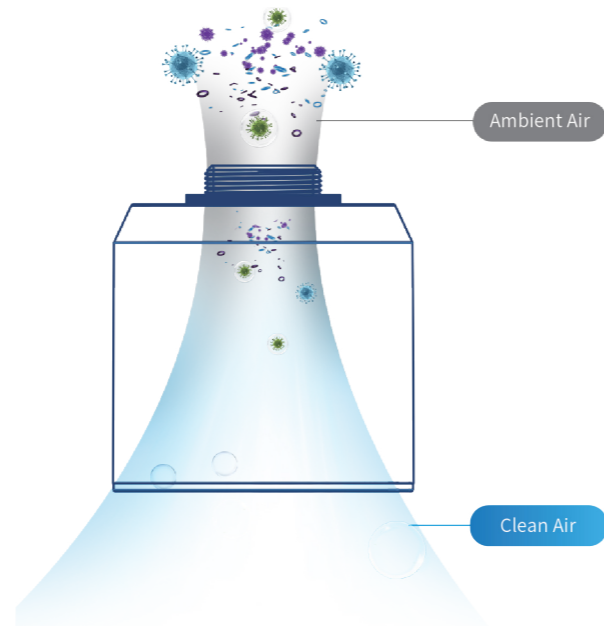

| Product Specifications      |                             |
|-----------------------------|-----------------------------|
| Inlet Filter Cartridge      |                             |
| Dimensions                  | Φ160×173mm                  |
| Threaded Port Compatibility | M61.6×2.5mm Threaded Port   |
| Efficiency                  | H14                         |
| Pressure Drop / Airflow     | 260Pa @ 50m <sup>3</sup> /h |
| Filter Media Area           | 0.76m <sup>2</sup>          |

## Isolator Exhaust Filter Cartridge



### PRODUCT DESCRIPTION

- High-efficiency filter designed for glove boxes and other isolation equipment
- Constructed with H14-rated high-efficiency glass fiber filter media
- Rated air volume: 35 m<sup>3</sup>/h
- Maximum continuous operating temperature: 110°C
- Specifically designed for push-push installation systems
- Suitable for filtering dust, bacteria, and aerosols in nuclear power and biopharmaceutical industries

### PRODUCT INSTALLATION

- **Installation Method:**  
Insert the two filters sequentially into the installation duct. The double-seal gasket ensures an airtight connection. To replace a used filter, simply push the new one in, which will eject the old filter
- **Precautions:**  
Before replacing the filter, shut off the airflow to balance internal and external pressure. This step is critical to prevent leakage or toxic dust.

### AIRFLOW VS. PRESSURE DROP

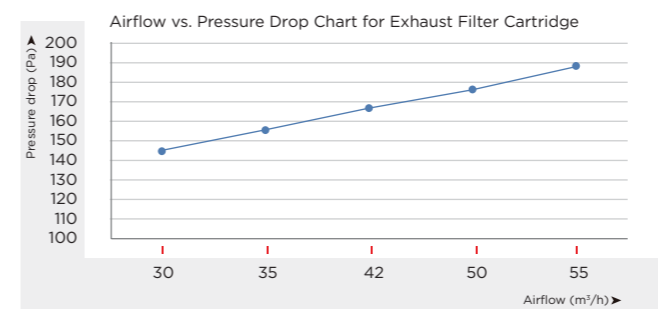

### WORKING PRINCIPLE

Working Principle of the Exhaust Filter Cartridge:

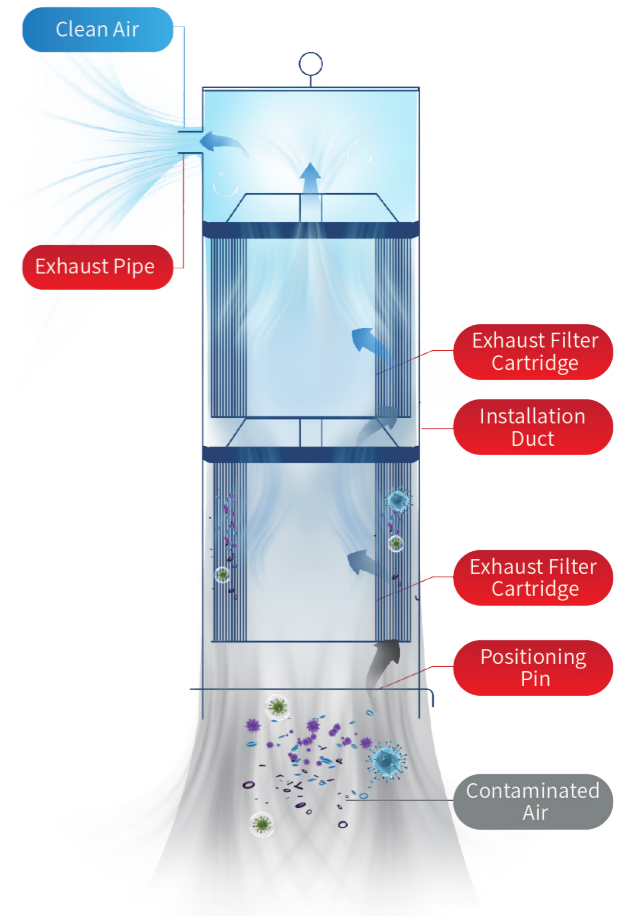

| Product Specifications      |  |
|-----------------------------|--|
| Inlet Filter Cartridge      |  |
| Dimensions                  | Φ153×162mm   |
| Threaded Port Compatibility | 150mm  |
| Efficiency                  | H14  |
| Pressure Drop / Airflow     | 260Pa @ 50m <sup>3</sup> /h / 16Pa @ 40m <sup>3</sup> /h |
| Filter Media Area           | 0.8m <sup>2</sup>  |

# FFU FAN FILTER UNIT



## PRODUCT FEATURES

- Diversified design to meet various cleanroom application needs
- Sleek, clean, and professional exterior appearance
- CE and UL fire safety certifications available upon request
- Equipped with a high-performance, low-noise external rotor backward-curved centrifugal fan
- Optimized internal airflow equalization design for stable performance
- Stable multi-speed control functionality
- Fully functional large-scale group control system
- Multiple optional features available for customized solutions

## STRUCTURAL FEATURES

- Ultra-thin, space-saving design
- Integrated liquid tank sealing and high-efficiency construction
- Test port included for convenient performance verification
- Bottom-mounted design for flexible installation
- European standard plug-in electrical connector
- Built-in HEPA/ULPA filter for superior air purification
- Dry coil design for enhanced hygiene and safety
- 10-speed adjustment for precise airflow control
- Remote control-enabled FFU
- Online monitoring of airflow velocity and pressure differential

## COMPANY ADVANTAGES

- Comprehensive FFU performance testing bench
- NH-1 acoustic and vibration measurement & analysis system
- Internal airflow cfd simulation capabilities for ffu
- FFU fan dynamic balancing laboratory
- High-efficiency filter performance testing platform

## STRUCTURAL DESCRIPTION

- **Liquid Tank Seal Type**  
**Advantage:** Superior sealing performance, suitable for environments requiring extremely high cleanliness standards  
**Disadvantage:** More complex installation and maintenance process
- **Mechanical Seal Type**  
**Advantage:** Easier installation and maintenance  
**Disadvantage:** Slightly lower sealing performance compared to liquid tank designs
- **Welded FFU**  
**Advantage:** Smooth surface for easy cleaning and reduced dust accumulation  
**Disadvantage:** Higher manufacturing cost
- **Riveted Type**  
**Advantage:** Cost-effective and suitable for mass production with faster lead times  
**Disadvantage:** Increased potential for dust accumulation

Illustrations of Various FFU Types



## TOUCH SCREEN TYPE I (For configurations with up to 31 FFU units)

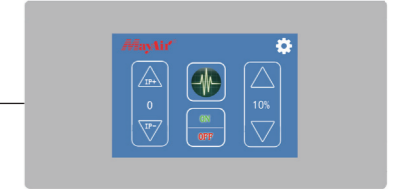
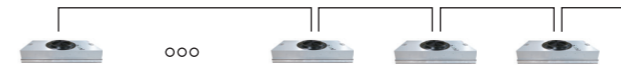

Touch Screen

### MayAir Multi-Unit FFU Touch Screen Type I

Equipped with a 3.5-inch, 65K high-resolution color display, this control panel allows stepless speed adjustment for up to 31 AC/DC fan units. It supports both group and individual control, offers real-time monitoring of fan status and speed, and displays key parameters such as airflow velocity and pressure differential. User access management is also integrated for enhanced security.

## Touch Screen Type II (For configurations with up to 500 FFU units)

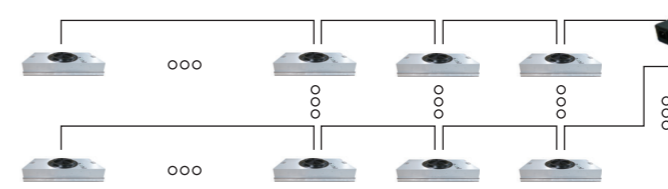

Zone Controller



Touch Screen

### MayAir Multi-Unit FFU Touch Screen Control System

Designed for localized workshop management in pharmaceutical environments, this advanced system provides flexible and comprehensive control of up to 500 AC/DC FFUs. It supports both group and individual unit control, includes user access management, and enables remote monitoring via RS485 communication when required. Ideal for scalable and secure cleanroom operations.

### Product Specifications

AC Motor Power Supply: 1Φ 220V-240V, 50Hz

| Series                     | F-22AL                 | F-23AL                 | F-24AL                   | F-24AM | F-34AM                   | F-34AM1 | F-44AM1                    | F-44AH |
|----------------------------|------------------------|------------------------|--------------------------|--------|--------------------------|---------|----------------------------|--------|
| W x L                      | 600 x 600<br>575 x 575 | 600 x 900<br>575 x 875 | 600 x 1200<br>575 x 1175 |        | 900 x 1200<br>875 x 1175 |         | 1200 x 1200<br>1175 x 1175 |        |
| H (mm)                     | 250                    | 250                    | 250                      | 275    | 275                      | 275     | 275                        | 275    |
| Air Velocity (m/s)         | 0.45                   | 0.45                   | 0.45                     | 0.45   | 0.45                     | 0.45    | 0.45                       | 0.45   |
| Total Static Pressure (Pa) | 250                    | 220                    | 210                      | 310    | 250                      | 275     | 205                        | 285    |
| Power (W)                  | 80                     | 110                    | 120                      | 155    | 175                      | 225     | 245                        | 305    |
| Noise (dBA)                | 50                     | 51                     | 52                       | 53     | 53.5                     | 53      | 55                         | 53.5   |
| Vibration (mm/s)           | 0.7                    | 0.8                    | 1.0                      | 1.0    | 1.2                      | 1.2     | 1.2                        | 1.2    |

DC Motor Power Supply: 1Φ 220V-240V, 50Hz

| Series                     | F-22EL                 | F-23EL                 | F-24EL                   | F-24EH | F-34EH                   | F-44EH                     |
|----------------------------|------------------------|------------------------|--------------------------|--------|--------------------------|----------------------------|
| W x L                      | 600 x 600<br>575 x 575 | 600 x 900<br>575 x 875 | 600 x 1200<br>575 x 1175 |        | 900 x 1200<br>875 x 1175 | 1200 x 1200<br>1175 x 1175 |
| H (mm)                     | 250                    | 250                    | 250                      | 275    | 275                      | 275                        |
| Air Velocity (m/s)         | 0.45                   | 0.45                   | 0.45                     | 0.45   | 0.45                     | 0.45                       |
| Total Static Pressure (Pa) | 270                    | 250                    | 210                      | 370    | 370                      | 360                        |
| Power (W)                  | 55                     | 70                     | 85                       | 90     | 125                      | 180                        |
| Noise (dBA)                | 49                     | 50.5                   | 51.5                     | 51     | 52.5                     | 53.5                       |
| Vibration (mm/s)           | 0.6                    | 0.6                    | 0.8                      | 0.8    | 0.8                      | 0.8                        |

## M-LC LIQUID SEAL LAMINAR HOOD



### PRODUCT OVERVIEW

The Laminar Flow Hood is a precision air purification unit designed to provide a localized high-cleanliness environment. It primarily consists of a housing, fan, high-efficiency filter, airflow equalization membrane, and lighting system. The unit can be installed either as a ceiling-mounted or floor-supported configuration and may operate independently or in series to form a continuous strip-shaped clean zone.

Filtered air is blown at a consistent velocity through a HEPA filter, then passes through the airflow equalization membrane to ensure a vertical, unidirectional flow of clean air, maintaining the cleanliness level required in the workspace.

Compared to traditional cleanrooms, the laminar flow hood offers several advantages, including lower capital investment, faster deployment, minimal structural requirements, ease of installation, and energy efficiency. It is widely adopted in industries such as precision machinery, electronics, pharmaceuticals, food processing, and fine chemicals.

In the pharmaceutical sector, laminar flow hoods are widely used and are available in two configurations: built-in fan type and externally connected fan type. Both options can be suspended from the ceiling or supported on a floor-mounted frame. In both configurations, a constant-pressure fan drives the airflow through a HEPA filter and then through the equalization membrane to deliver uniform vertical laminar flow, meeting stringent cleanliness standards for critical processes.



### PRODUCT FEATURES

- Compliant with GMP validation requirements
- Grade A (GMP-compliant) clean zone
- Fully constructed from SUS304 stainless steel
- Compatible with both high-airflow fan supply and centralized air-conditioning supply
- Liquid tank seal design ensures zero leakage

### CONTROL DESCRIPTION

The system is operated via a touchscreen control panel, providing real-time display of operational parameters such as fan status, airflow velocity, and pressure differential. When connected to a particle counter, the system also supports real-time monitoring and display of airborne particle concentrations.

### CLEANLINESS CLASS

- Grade A (GMP Compliant)

| Product Specifications       |                            |
|------------------------------|----------------------------|
| Cleanliness Class            | Grade A                    |
| Filter Efficiency            | H14 99.995%@MPPS           |
| Sealing Type                 | Negative Pressure Gel Seal |
| Working Surface Air Velocity | 0.36-0.54 m/s              |
| Noise Level                  | ≤65 dB(A)                  |
| Illuminance                  | ≥350 lux                   |
| Overall Material             | SUS304 Stainless Steel     |

### WORKING PRINCIPLE

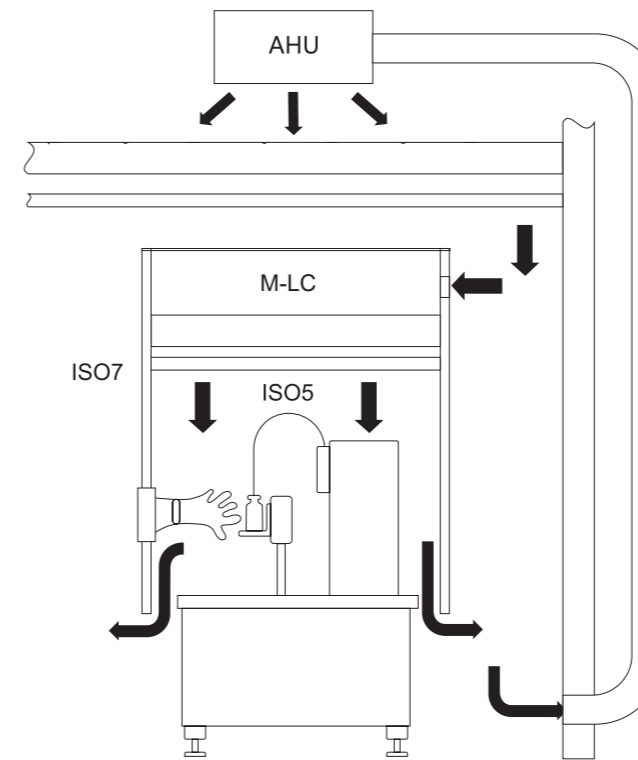

### PRODUCT STRUCTURE DESCRIPTION

The laminar flow hood is entirely constructed from SUS304 stainless steel and features a liquid tank seal to guarantee airtight performance. It provides vertical unidirectional airflow, with an optional airflow equalization membrane at the air outlet. The airflow velocity ranges from 0.36 to 0.54 m/s, and its performance can be verified using smoke testing.

The unit includes PAO aerosol injection and upstream sampling ports to facilitate on-site filter integrity testing. The side isolation panels are made from either anti-static polycarbonate (PC) or tempered glass, offering visibility and containment.



## M-DB WEIGHING BOOTH



### PRODUCT OVERVIEW

The M-DB Weighing Booth is a specialized local purification unit designed for use in pharmaceutical production facilities, microbiological laboratories, and scientific research environments. It delivers vertical unidirectional airflow, with a portion of the clean air recirculated and the remainder exhausted, creating a negative pressure zone in the workspace. This setup effectively prevents cross-contamination and ensures a highly controlled clean environment within the weighing area.

### PRODUCT FEATURES

- Ensures operator safety
- Prevents dust and particle leakage
- Eliminates cross-contamination risks
- Protects product integrity
- Maintains room pressure balance

### STRUCTURAL DESCRIPTION

Constructed entirely from SUS304 stainless steel, the unit comprises an upper cabinet, lower cabinet, and detachable side panels for ease of transport and modular assembly. The system utilizes a vertical unidirectional airflow design, where approximately 85%–90% of the air passes through an airflow equalization membrane to form a consistent vertical laminar flow. The remaining 10%–15% is discharged through an exhaust outlet to maintain negative pressure within the working area.

### APPLICATIONS

- Used in pharmaceutical manufacturing, microbiological institutes, and scientific research.

| Product Specifications         |  |
|--------------------------------|--|
| Cleanliness Class              | Grade A  |
| Filter Efficiency              | Primary Filter G4, Secondary Filter F8, HEPA Filter H14 99.995%@MPPS |
| Average Air Velocity (m/s)     | 0.45±20%   |
| Noise Level (dB(A))            | ≤ 70   |
| Overall Material               | SUS 304  |
| Work Surface Illuminance (LUX) | ≥ 350  |

Notes: DQ, FAT, IQ, OQ, SAT and other related qualification services can be provided upon customer request.

### STRUCTURAL DIAGRAM

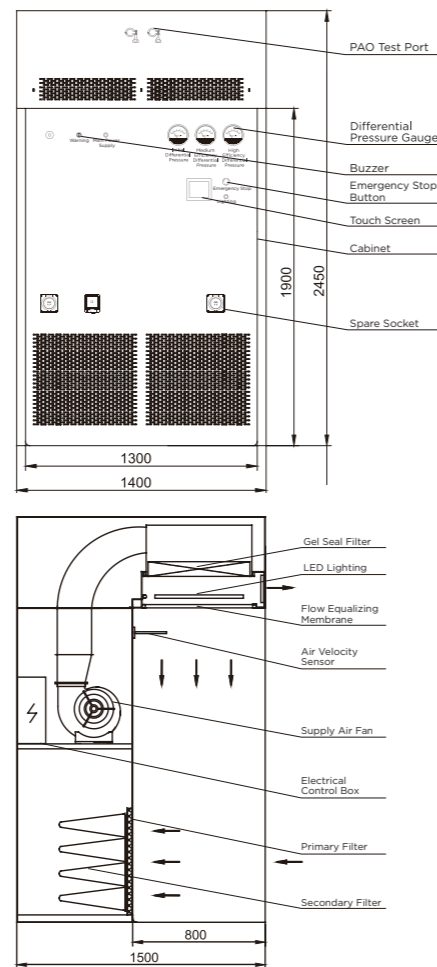

## LARGE-SPACE HYDROGEN PEROXIDE STERILIZER



### PRODUCT OVERVIEW

The Large-Space Hydrogen Peroxide Sterilizer utilizes flash vaporization technology to convert 35% hydrogen peroxide solution into vapor, which is evenly distributed throughout the sterilization area via a high-performance built-in fan. This ensures comprehensive, residue-free sterilization—even in hard-to-reach corners. After the sterilization process, the hydrogen peroxide is rapidly decomposed, leaving no toxic residues.

This system incorporates MayAir's patented vaporization control method, making it ideal for large-area sterilization as well as for biosafety equipment featuring single or dual-stage HEPA filtration systems.

### PRODUCT FEATURES

- Equipped with a high-air-volume, high-pressure fan for effective sterilization of large spaces
- Seamless transition between space sterilization and equipment sterilization, no additional accessories required
- Intelligent control system automatically adjusts hydrogen peroxide flow rate by sterilization phase, minimizing waste
- Supports remote operation and real-time monitoring of sterilization progress and parameters
- Integrated weight sensor provides real-time feedback on hydrogen peroxide levels, with automatic refill alerts

### STRUCTURAL DIAGRAM

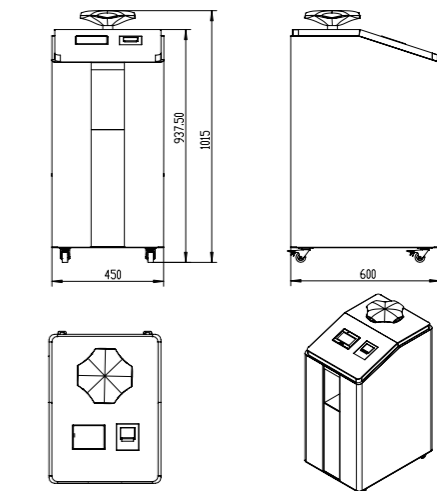

### APPLICATIONS

- Widely used in sterile rooms, biosafety cabinets, and other spaces or equipment requiring sterilization.

| Product Specifications                                  |   |
|---|---|
| Cleanliness Class                                       | 450mm × 600mm × 1100mm  |
| Power Supply  | AC 220V 50HZ  |
| Power (W)   | 1,200W  |
| Airflow (m³/h)  | 50m³/h  |
| Sterilization Volume (m³)                               | 300   |
| Sterilization Effectiveness                             | 6 log   |
| Sterilization Concentration                             | 200-350ppm  |
| Residual VHP Concentration Standard After Sterilization | ≤ 1ppm  |
| Sterilization Time (min)                                | 30-60 min (adjustable based on sterilization space)                   |
| Decomposition Time (min)                                | 60-120 minutes (to reach ≤1 ppm VHP concentration post-sterilization) |
| Equipment Material                                      | SUS304  |
| Air Inlet / Outlet Dimensions (mm)                      | DN25 Tri-Clamp connector / Diffusion nozzle                           |
| Weight (kg)   | 50  |



## PASS BOX

### REGULAR PASS BOX/ CLEAN PASS BOX

#### PRODUCT OVERVIEW

The pass box is an auxiliary device used in cleanrooms, designed primarily for transferring small items between clean and non-clean areas. It helps minimize the frequency of door openings, thereby reducing the risk of contamination in the clean area to the lowest possible level.

#### PASS BOX CONFIGURATION

- Constructed from SUS304 stainless steel with a fully arc-shaped interior for easy cleaning
- Equipped with PAO injection and test ports using 304 stainless steel quick-connect fittings
- H14 gel-seal HEPA filter with high-efficiency differential pressure gauge
- UV sterilization lamp with adjustable sterilization time, timer, and cumulative runtime display; UV can be set to activate simultaneously with the fan
- Custom-developed LCD controller with electromagnetic door interlock; supports manual and automatic modes with configurable functions, time display, and call feature
- Optional fan auto-start upon door closure
- Built-in double-layer black-edged tempered glass doors with integrated desiccant
- Custom fan with adjustable operation duration
- Fresh air inlet from the clean side to maintain positive pressure; air supply volume is adjustable
- Custom designs available upon request

#### PRODUCT FEATURES

- Entire cabinet made of SUS304 stainless steel, featuring arc-shaped corners for cleanliness and easy maintenance
- Dual-door interlock system prevents both doors from being opened simultaneously
- Built-in double-layer tempered glass viewing windows
- Clean pass box version includes automatic air shower function to effectively remove surface dust during item transfer

#### APPLICATIONS

- Primarily used for transferring small items between cleanrooms or between clean and non-clean areas, reducing door openings and minimizing contamination risk within clean environments.

| Product Specifications |                            |                                |
|------------------------|----------------------------|--------------------------------|
| Product Name           | Overall Dimensions (W×D×H) | Internal Dimensions (W1×D1×H1) |
| Standard Pass Box      | 800 × 660 × 760            | 600 × 600 × 600                |
| Clean Pass Box         | 800 × 660 × 1130           | 600 × 600 × 600                |

| Optional Accessories |                                     |                 |
|----------------------|-------------------------------------|-----------------|
| Lighting lamp        | Digital differential pressure gauge | Intercom system |



## VHP PASS BOX

#### PRODUCT OVERVIEW

The VHP Pass Box integrates a Vaporized Hydrogen Peroxide (VHP) generator, which delivers hydrogen peroxide gas into the chamber for surface bio-decontamination of materials. This prevents contamination from being introduced into Grade A or B critical areas from non-classified zones or lower-grade clean areas.

VHP Pass Boxes utilize the superior sporicidal efficacy of hydrogen peroxide in its vapor phase at room temperature. Through oxidative-reductive reactions, hydrogen peroxide decomposes into highly reactive hydroxyl radicals that disrupt cell membranes, including lipids, proteins, and DNA, effectively replacing traditional UV disinfection and achieving complete sterilization.

#### PRODUCT FEATURES

- Single sterilization cycle takes less than 120 minutes, allowing multiple cycles per day
- Uses compressed air for rapid dehumidification and filter penetration, minimizing condensation
- Integrated catalytic decomposer accelerates VHP breakdown, allowing direct exhaust to the duct system
- Real-time batch data can be recorded, printed, and exported for review and traceability
- Inflatable door gaskets ensure chamber airtightness; an automatic leak test is performed before each cycle

| Product Specifications                |   |
|---------------------------------------|---|
| Main Structure                        | SUS304 stainless steel + Tempered glass |
| Gasket                                | Silicone rubber / Fluororubber          |
| Hepa Filter                           | H14                                     |
| Sterilizing Agent                     | 35 % H <sub>2</sub> O <sub>2</sub>      |
| Noise Level                           | ≤ 65 dB                                 |
| Power Supply                          | AC380V / AC220V / 50Hz                  |
| Air Supply Pressure                   | 0.6-0.8 MPa                             |
| Sterilization Cycle Time              | < 120 min                               |
| Sterilization Capacity                | 6 log                                   |
| H <sub>2</sub> O <sub>2</sub> Residue | < 1 ppm                                 |

#### APPLICATIONS

- Widely used in the pharmaceutical industry, biopharmaceuticals, biosafety laboratories, hospitals, and other controlled environments requiring high-level surface sterilization

#### PRODUCT STRUCTURE DESCRIPTION

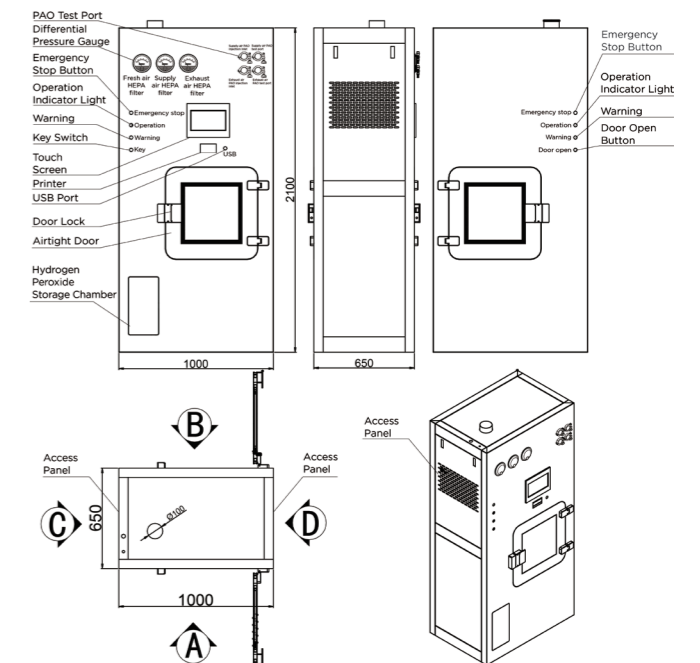

# BEHU BIOSAFETY EXHAUST HEPA UNIT



## PRODUCT FEATURES

- Designed for use in negative pressure isolation zones, vaccine production facilities, high-potency pharmaceutical operations, biosafety laboratories, and other environments requiring filtered exhaust air
- Housing material options: Stainless steel or coated carbon steel to suit various environmental conditions
- Equipped with standard pressure differential gauges for real-time monitoring of filter pressure; optional remote signal transmission available
- Can be configured with a PAO scanning system for in-situ filter leak detection
- Optional biosafety isolation valve ensures safe closure of ventilation pipelines
- Disinfection ports and access panels available to allow internal decontamination, enhancing safety for testing and maintenance personnel

## PERFORMANCE INDICATORS

- **Enclosure Airtightness:**  
Each unit is factory-tested. Leakage rate at -2,500 Pa must not exceed 0.1% per minute
- **Pressure Resistance:**  
Withstands  $\geq 2,500$  Pa for a minimum duration of 60 minutes
- **Filtration Efficiency:**  
 $\geq 99.995\%$  @ MPPS (Most Penetrating Particle Size)
- **Leak Detection Method:**  
Supports in-situ scanning leak detection (manual or automatic)

## AIR TIGHTNESS

The BEHU is manufactured using full-seam welding technology, capable of withstanding pressure ranges between 1,000 to 5,000 Pa (depending on housing thickness).

Airtightness performance complies with the following standards:

- GB 19489-2008 (General Requirements for Laboratory Biosafety)
- ISO 10648-2 (Classification According to Leak Tightness and Checking Methods)
- JG/T 497-2016 (Exhaust High-Efficiency Filtration Devices)

Each unit undergoes comprehensive airtightness testing prior to factory dispatch to ensure compliance with national or customer-specified standards.

## STRUCTURAL DIAGRAM

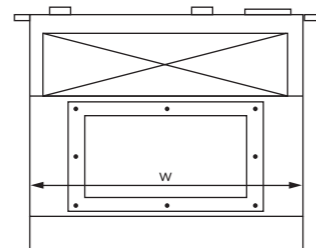
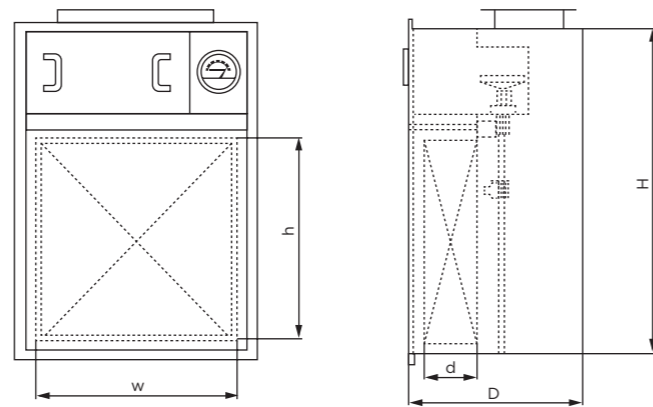

## NAME SPECIFICATION

BEHU01 - □□□ - □□□ - □□□ - □□□

- 1 Optional Accessories: 0-No optional accessories, MS-Manual scanning function, AS-Automatic scanning function, PG-with differential pressure gauge, F-Fumigation port, TB-Test panel (includes PAO test port and disinfection test port)
- 2 Air Outlet Type / Air Outlet Size: 01-Round top outlet, 02-Round side outlet, 03-Square top outlet, 04-Square side outlet  
Length × Width (X×Y) / Diameter (X), unit: mm
- 3 Filter Structure / Filter Thickness: EPU3-Integrated outlet face gasket, U3-Outlet face gel seal (top gel channel) 70 mm, 80 mm, 90 mm, 100 mm, 110 mm, 292 mm
- 4 Housing Material: SP-SPCC, SS-SUS304, 5-1.5 mm, 6-2.0 mm
- 5 Product Dimensions: Height × Width × Depth (H×W×D), unit: mm
- 6 BEHU-Biosafety Exhaust HEPA Unit

## INTEGRITY TESTING OF HEPA FILTERS

The BEHU is designed with quick-connect valves that allow for rapid connection to instruments such as photometers during on-site operations. This setup enables in-situ integrity scanning and leak testing of HEPA filters without interrupting equipment operation.

To ensure accurate and reliable results, the sampling probe of the scanning device is positioned no more than 25 mm from the filter outlet surface. The scanning system is compatible with both manual and motorized operation, providing flexibility based on testing requirements.

| Product Specifications          |                             |                                     |                                       |
|---------------------------------|-----------------------------|-------------------------------------|---------------------------------------|
| Product Model                   | Airflow (m <sup>3</sup> /h) | Enclosure Dimensions H x W x D (mm) | Filter Dimensions W x H x D (mm)      |
| BEHU01 - 680 x 665 x 500 - SS6  | 0 - 500                     | 680 x 665 x 500                     | 610 x 305 x 70 / 80 / 90 / 100 / 110  |
| BEHU01 - 680 x 970 x 500 - SS6  | 501 - 1,000                 | 680 x 970 x 500                     | 610 x 610 x 70 / 80 / 90 / 100 / 110  |
| BEHU01 - 985 x 970 x 500 - SS6  | 1,001 - 1,500               | 985 x 970 x 500                     | 915 x 610 x 70 / 80 / 90 / 100 / 110  |
| BEHU01 - 1290 x 970 x 500 - SS6 | 1,501 - 2,000               | 1290 x 970 x 500                    | 1220 x 610 x 70 / 80 / 90 / 100 / 110 |

Note: The above models are based on 2.0 mm stainless steel sheet metal. Enclosure dimensions do not include flanging. HEPA filters are mini-pleated by default. Models 80/100 are equipped with liquid trough filters, while other models use integrated gasket filters. For higher airflow requirements (2,000-3,400 m<sup>3</sup>/h), it is recommended to select separator filters with a thickness of 292 mm, increasing the enclosure thickness to 650 mm.

## INSTALLATION METHOD

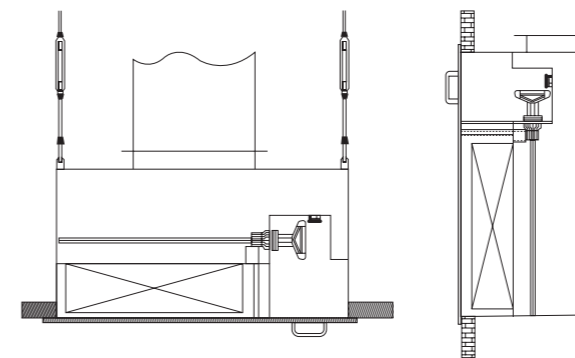

The BEHU can be installed in two configurations based on the return air duct design: suspended (see left image, 1) or side wall-mounted (see right image, 2).

# M-BIBO BAG-IN BAG-OUT (BIBO) CONTAINMENT SYSTEM

## PRODUCT FEATURES

- Modular design for enhanced flexibility
- Professionally laser-welded construction
- Frame available in coated steel or stainless steel
- Equipped with PAO injection and sampling ports, supporting filter scanning
- 100% factory tested; on-site testing services available
- Optional accessories include polypropylene replacement bags, pressure gauges, biosafety dampers, and pre-filters

## STRUCTURAL FEATURES

- **Modular Configuration for Flexible Assembly Based on Airflow and Installation Space**  
The BIBO system consists of multiple filter unit modules, assembled according to airflow requirements. Each module features a standardized size and structure. Core components include pre-filters, HEPA filters, service doors, change-out bags, scanning detection devices, and biosafety shut-off valves. Auxiliary elements such as pressure gauges, PAO aerosol dispersion units, and quick-connect ports ensure complete system functionality. These modules can be arranged flexibly to accommodate site constraints.
- **Versatile Biosafety Shut-off Valve Options**  
The BIBO system connects to the exhaust duct via biosafety shut-off valves, available in both rectangular and circular configurations to match customer ductwork requirements.
- **Precision Welding for Structural Reliability**  
Each BIBO module is fabricated with CNC cutting, CNC lathe processing, and full-seam welding. Specially designed clamping mechanisms secure the filters in place, ensuring optimal sealing performance and structural strength.



## APPLICATIONS

The BIBO system is widely used in high-containment or hazardous exhaust scenarios, including:

- Chemical and biological (CB) protection
- Chemical, biological, and radiological (CBR) defense
- Nuclear, biological, and chemical (NBC) containment
- Hospital isolation rooms and pharmaceutical equipment
- Microelectronics production and food processing facilities
- Biological research and genetic engineering laboratories
- Industrial emission control and chemical processing systems
- Animal disease research labs and radioactive isotope handling
- Nuclear power plants, D.O.E. facilities, and military bases

The BIBO containment system ensures pollutants are not released during operation. All filter installations, replacements, and testing are conducted within a sealed change-out bag, fully isolating the filter unit from personnel and the surrounding environment, protecting both workers and public health.

## PRODUCT STRUCTURE DESCRIPTION

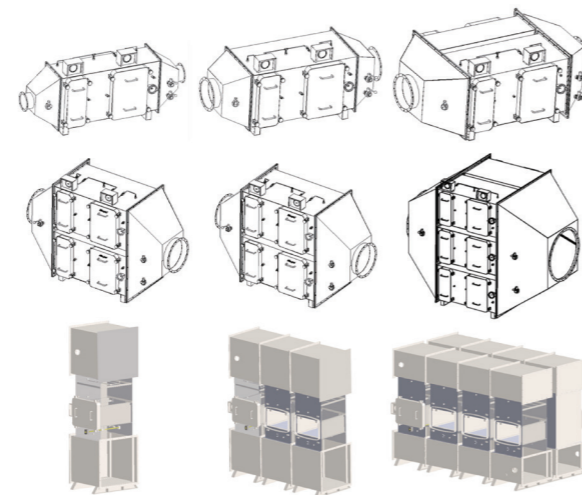

## NAME SPECIFICATION

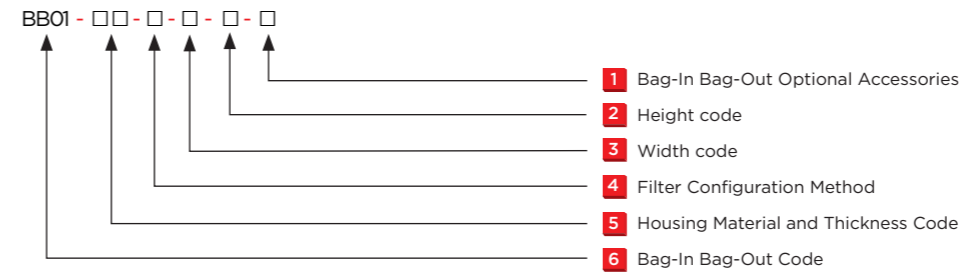

## PRODUCT TESTING

In accordance with JG/T497-2016, GB19489-2008, and GB50346-2011 standards, every MayAir BIBO system undergoes comprehensive factory testing to ensure compliance with required safety protection levels. These tests include pressure resistance, enclosure leak tests, PAO scanning, and more. Each unit is delivered with accompanying BIBO and filter test reports.

Optional features such as manual or automatic PAO scanning, biosafety-sealed valves, and fumigation ports enable on-site leak detection and ventilation system decontamination based on customer requirements. MayAir BIBO systems have successfully passed P3/P4 biosafety compliance, performance testing, and disinfection validation, with inspection reports certified by accredited third-party institutions.



| Product Specifications         |   |
|--------------------------------|---|
| Housing Material and Thickness | SP-SPCC (Cold-Rolled steel), SS-SUS304 (Stainless steel); Thickness: 2.0mm, 3.0mm   |
| Filter Combination Method      | PMH, MH, PH, PM, M, H<br>(P = Primary Filter, 46 mm; M = Medium Efficiency, 90 mm; H = HEPA Filter, 292 mm)                     |
| Airflow                        | 1,700 / 3,400 / 6,800 / 8,500 / 10,200 / 13,600 / 17,000...   |
| Housing Type                   | Horizontal / Vertical / Side-wall mounted / Customized forms per customer specs   |
| Optional Accessories           | Transition ducts, fumigation ports, biosafety-sealed valves, manual/automatic scanning mechanisms, differential pressure gauges |



## AUTOROLL STRAIGHT/ V-SHAPED AUTOROLL FILTER

### PRODUCT FEATURES

- Automated filter media replacement
- Differential pressure-based control
- Modular assembly for flexible installation
- Simple and robust design
- Durable metal construction suitable for harsh environments
- Intelligent filter replacement system optimizes airflow, reducing energy and labor costs

### APPLICATIONS

- Primary pre-filtration stage for industrial ventilation and air conditioning systems
- Environments with high dust loads requiring frequent filter media replacement
- Systems operating under constant air volume conditions

### EFFICIENCY

- G3, G4

### V-SHAPE DESIGN

- The filter media is configured in a "V" shape to increase the effective filtration area while reducing resistance
- Patented sealing design ensures superior airtightness
- Filtration area is effectively doubled, and initial resistance is reduced by half

### PRODUCT STRUCTURE DESCRIPTION

- Differential Pressure Monitoring:** The system detects when the filter media requires replacement by monitoring differential pressure. This avoids waste due to manual errors and ensures optimal filtration efficiency and economical operation.
- Dual Control by Time and Pressure:** Dual-mode control (based on time and/or differential pressure) prevents premature rolling of clean filter media, minimizing unnecessary waste.
- Filter Media Exhaust Warning:** An indicator light alerts the user when the roll of filter media is nearing depletion, prompting timely replacement.
- Flexible Modular Assembly:** The unit can function independently or be combined in multiple units to accommodate large-area ventilation requirements.

| Materials Table   |   |
|-------------------|---|
| Frame             | Cold-rolled steel plate with surface spray treatment for durability |
| Upper Filter Box  | Sealed structure to prevent contamination of clean filter media     |
| Lower Filter Roll | Dirty filter material on the wound filter surface                   |
| Control Cabinet   | Includes logo, PCB control device, and control circuitry            |
| Motor Drive Unit  | Compatible with applicable voltage requirements                     |
|                   | Power   |
| Filter Material   | Synthetic fiber, 10mm thickness, 15 meters per roll                 |

| Applicable Conditions |               |
|-----------------------|---------------|
| Maximum Temperature   | -10°C ~ +40°C |

| Detailed Control Functions |   |
|----------------------------|---|
| Standard Features          | Power indicator                                       |
|                            | Motor protection                                      |
|                            | Filter material alarm indicator                       |
|                            | Manual and automatic operation modes                  |
| Optional Features          | Differential pressure digital display                 |
|                            | Filter media alarm signal output (passive contact)    |
|                            | Motor running / fault signal output (passive contact) |

### NAME SPECIFICATION

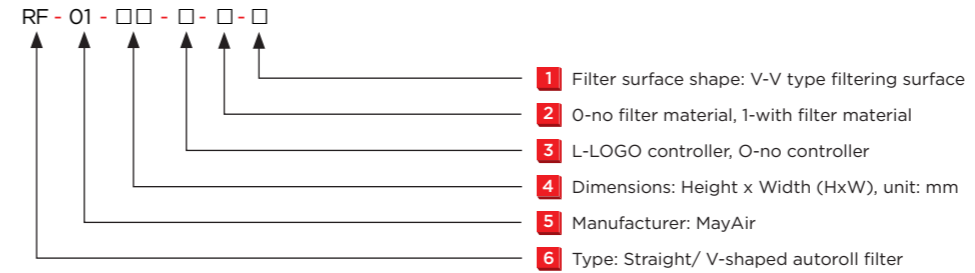

| Straight Auto Roll Filter             |   |          |          |          |          |           |           |           |           |           |           |  |
|---------------------------------------|---|----------|----------|----------|----------|-----------|-----------|-----------|-----------|-----------|-----------|--|
| Total Width of The Filter Inches (mm) | Airflow (m <sup>3</sup> /h)             |          |          |          |          |           |           |           |           |           |           |  |
|                                       | Total Height of The Filter in Feet (mm) |          |          |          |          |           |           |           |           |           |           |  |
|                                       | 5(1,524)                                | 6(1,829) | 7(2,134) | 8(2,438) | 9(2,743) | 10(3,048) | 11(3,353) | 12(3,658) | 13(3,962) | 14(4,267) | 15(4,572) |  |
| 03(914)                               | 8,766                                   | 11,083   | 13,399   | 15,709   | 18,025   | 20,342    | 22,659    | 24,976    | 27,285    | 29,602    | 31,918    |  |
| 04(1,219)                             | 11,934                                  | 15,088   | 18,242   | 21,385   | 24,539   | 27,693    | 30,847    | 34,001    | 37,145    | 40,299    | 43,453    |  |
| 05(1,524)                             | 15,101                                  | 19,092   | 23,084   | 27,062   | 31,053   | 35,044    | 39,036    | 43,027    | 47,005    | 50,996    | 54,987    |  |
| 06(1,829)                             | 18,269                                  | 23,097   | 27,926   | 32,739   | 37,567   | 42,395    | 47,224    | 52,052    | 56,865    | 61,693    | 66,522    |  |
| 07(2,134)                             | 20,710                                  | 26,183   | 31,657   | 37,112   | 42,586   | 48,059    | 53,533    | 59,006    | 64,462    | 69,936    | 75,409    |  |
| 08(2,438)                             | 23,867                                  | 30,175   | 36,483   | 42,770   | 49,078   | 55,386    | 61,694    | 68,002    | 74,290    | 80,598    | 86,906    |  |
| 09(2,743)                             | 27,035                                  | 34,180   | 41,325   | 48,447   | 55,592   | 62,738    | 69,883    | 77,028    | 84,150    | 91,295    | 98,440    |  |
| 10(3,048)                             | 30,202                                  | 38,185   | 46,167   | 54,124   | 62,106   | 70,089    | 78,071    | 86,054    | 94,010    | 101,992   | 109,975   |  |
| 11(3,353)                             | 33,370                                  | 42,190   | 51,010   | 59,800   | 68,620   | 77,440    | 86,259    | 95,079    | 103,870   | 112,690   | 121,509   |  |
| 12(3,658)                             | 35,811                                  | 45,276   | 54,740   | 64,174   | 73,639   | 83,104    | 92,568    | 102,033   | 111,467   | 120,932   | 130,396   |  |
| 13(3,962)                             | 38,968                                  | 49,268   | 59,567   | 69,832   | 80,131   | 90,431    | 100,730   | 111,029   | 121,295   | 131,594   | 141,893   |  |
| 14(4,267)                             | 42,136                                  | 53,272   | 64,409   | 75,509   | 86,645   | 97,782    | 108,918   | 120,055   | 131,155   | 142,291   | 153,428   |  |
| 15(4,572)                             | 45,304                                  | 57,277   | 69,251   | 81,186   | 93,159   | 105,133   | 117,107   | 129,080   | 141,015   | 152,988   | 164,962   |  |
| 16(4,877)                             | 48,471                                  | 61,282   | 74,093   | 86,862   | 99,673   | 112,484   | 125,295   | 138,106   | 150,875   | 163,686   | 176,497   |  |
| 17(5,182)                             | 51,639                                  | 65,287   | 78,935   | 92,539   | 106,187  | 119,835   | 133,483   | 147,131   | 160,735   | 174,383   | 188,031   |  |
| 18(5,486)                             | 54,797                                  | 69,279   | 83,762   | 98,197   | 112,680  | 127,162   | 141,645   | 156,127   | 170,563   | 185,045   | 199,528   |  |
| 19(5,791)                             | 57,964                                  | 73,284   | 88,604   | 103,874  | 119,193  | 134,513   | 149,833   | 165,153   | 180,423   | 195,742   | 211,062   |  |
| 20(6,090)                             | 61,070                                  | 77,210   | 93,351   | 109,439  | 125,579  | 141,720   | 157,860   | 174,001   | 190,089   | 206,229   | 222,370   |  |
| 21(6,401)                             | 64,300                                  | 81,294   | 98,288   | 115,227  | 132,221  | 149,215   | 166,210   | 183,204   | 200,143   | 217,137   | 234,131   |  |
| 22(6,706)                             | 67,467                                  | 85,299   | 103,130  | 120,904  | 138,735  | 156,567   | 174,398   | 192,230   | 210,003   | 227,834   | 245,666   |  |
| 23(7,010)                             | 70,625                                  | 89,291   | 107,957  | 126,562  | 145,228  | 163,894   | 182,560   | 201,226   | 219,830   | 238,496   | 257,162   |  |
| 24(7,315)                             | 73,793                                  | 93,296   | 112,799  | 132,238  | 151,741  | 171,245   | 190,748   | 210,251   | 229,690   | 249,194   | 268,697   |  |

Remark:

- The airflow values above are calculated at a wind speed of 2.5m/s.
- When the width is greater than >0.6ft, multiple units are assembled.
- Non-standard sizes can be customized.

| V-Shaped Auto Roll Filter             |   |          |          |          |          |           |           |           |           |           |           |  |
|---------------------------------------|---|----------|----------|----------|----------|-----------|-----------|-----------|-----------|-----------|-----------|--|
| Total Width Of The Filter Inches (mm) | Airflow (m <sup>3</sup> /h)             |          |          |          |          |           |           |           |           |           |           |  |
|                                       | Total Height of The Filter in Feet (mm) |          |          |          |          |           |           |           |           |           |           |  |
|                                       | 5(1,524)                                | 6(1,829) | 7(2,134) | 8(2,438) | 9(2,743) | 10(3,048) | 11(3,353) | 12(3,658) | 13(3,962) | 14(4,267) | 15(4,572) |  |
| 03(914)                               | 9,620                                   | 13,053   | 16,487   | 19,920   | 23,354   | 26,787    | 30,221    | 33,654    | 37,088    | 40,521    | 43,955    |  |
| 04(1,219)                             | 13,134                                  | 17,822   | 22,509   | 27,197   | 31,884   | 36,572    | 41,259    | 45,947    | 50,634    | 55,322    | 60,011    |  |
| 05(1,524)                             | 16,649                                  | 22,590   | 28,532   | 34,473   | 40,415   | 46,358    | 52,299    | 58,241    | 64,182    | 70,124    | 76,067    |  |
| 06(1,829)                             | 20,162                                  | 27,359   | 34,554   | 41,750   | 48,947   | 56,142    | 63,338    | 70,533    | 77,730    | 84,926    | 92,123    |  |
| 07(2,134)                             | 23,676                                  | 32,126   | 40,577   | 49,026   | 57,477   | 65,927    | 74,378    | 82,827    | 91,278    | 99,728    | 108,179   |  |
| 08(2,438)                             | 27,191                                  | 36,894   | 46,599   | 56,303   | 66,008   | 75,713    | 85,416    | 95,121    | 104,825   | 114,530   | 124,235   |  |
| 09(2,743)                             | 30,704                                  | 41,663   | 52,622   | 63,579   | 74,538   | 85,497    | 96,456    | 107,414   | 118,373   | 129,332   | 140,291   |  |
| 10(3,048)                             | 34,218                                  | 46,431   | 58,644   | 70,857   | 83,069   | 95,282    | 107,495   | 119,708   | 131,921   | 144,132   | 156,347   |  |
| 11(3,353)                             | 37,733                                  | 51,200   | 64,667   | 78,134   | 91,601   | 105,068   | 118,533   | 132,000   | 145,467   | 158,934   | 172,403   |  |
| 12(3,658)                             | 41,246                                  | 55,968   | 70,689   | 85,410   | 100,131  | 114,852   | 129,573   | 144,294   | 159,015   | 173,736   | 188,459   |  |
| 13(3,962)                             | 44,760                                  | 60,735   | 76,712   | 92,687   | 108,662  | 124,637   | 140,612   | 156,588   | 172,563   | 188,538   | 204,515   |  |
| 14(4,267)                             | 48,275                                  | 65,504   | 82,734   | 99,963   | 117,192  | 134,423   | 151,652   | 168,881   | 186,110   | 203,340   | 220,571   |  |
| 15(4,572)                             | 51,789                                  | 70,272   | 88,755   | 107,240  | 125,723  | 144,207   | 162,690   | 181,175   | 199,658   | 218,142   | 236,627   |  |
| 16(4,877)                             | 55,302                                  | 75,041   | 94,778   | 114,516  | 134,255  | 153,992   | 173,730   | 193,467   | 213,206   | 232,943   | 252,681   |  |
| 17(5,182)                             | 58,817                                  | 79,809   | 100,800  | 121,793  | 142,785  | 163,776   | 184,769   | 205,761   | 226,754   | 247,745   | 268,737   |  |
| 18(5,486)                             | 62,331                                  | 84,576   | 106,823  | 129,069  | 151,316  | 173,562   | 195,809   | 218,054   | 240,300   | 262,547   | 284,793   |  |
| 19(5,791)                             | 65,844                                  | 89,345   | 112,845  | 136,346  | 159,846  | 183,347   | 206,847   | 230,348   | 253,848   | 277,349   | 300,849   |  |
| 20(6,090)                             | 69,359                                  | 94,113   | 118,868  | 143,622  | 168,377  | 193,131   | 217,887   | 242,640   | 267,396   | 292,151   | 316,905   |  |
| 21(6,401)                             | 72,873                                  | 98,882   | 124,890  | 150,899  | 176,909  | 202,917   | 228,926   | 254,934   | 280,943   | 306,953   | 332,961   |  |
| 22(6,706)                             | 76,386                                  | 103,650  | 130,913  | 158,175  | 185,439  | 212,702   | 239,964   | 267,228   | 294,491   | 321,755   | 349,017   |  |
| 23(7,010)                             | 79,901                                  | 108,419  | 136,935  | 165,453  | 193,970  | 222,486   | 251,004   | 279,522   | 308,093   | 336,555   | 365,073   |  |
| 24(7,315)                             | 83,415                                  | 113,186  | 142,958  | 172,730  | 202,500  | 232,272   | 262,043   | 291,815   | 321,587   | 351,357   | 381,129   |  |

Note: When the width is greater than >0.6ft, multiple units are assembled.



GLOBAL CLEANTECH SOLUTIONS PROVIDER

[www.mayairgroup.com](http://www.mayairgroup.com) | [www.mayair.com.my](http://www.mayair.com.my) | [www.mayair.us](http://www.mayair.us)

**Corporate Headquarters (HQ)**

**MayAir Manufacturing (M) Sdn. Bhd.**

No.35, Jalan P4/6, Seksyen 4, Bandar Teknologi Kajang,  
43500 Semenyih, Selangor, Malaysia.

Tel : +603-8210-7373  
Fax : +603-8210-7337  
Email : [info@mayair.com.my](mailto:info@mayair.com.my)

**MayAir (Thailand) Co. Ltd.**

343, Neighbour Center, Room 107 1st Floor,  
Watcharaphol Road, Tha Raeng, Bangkok,  
Bangkok, 10220, Thailand.

Tel : +66-02-004-9686

**MayAir Singapore Pte. Ltd.**

No.63, Jalan Pemimpin,  
#03-02, Singapore 577219, Singapore.

Tel : +65-6275-7068

**MayAir Inc.**

698 12th Street SE STE 200,  
Salem, OR 97301, United States.

Tel : +1 (424) 502-9199

Scan here for digital copy:



Authorized Representative:

MayAir reserves the right to make changes in the product specifications, designs and technical information or discontinue any of the products at any time without prior notice. Please contact our sales representatives for the latest product information at your convenience.