

科技创新 技术制胜
Science and technology innovation Technology to win



燕加隆科技

YANJIALONG TECHNOLOGY

工业废水治理蒸发设备
化工生产蒸发结晶设备
污泥干化设备



燕加隆机械科技（江苏）有限公司

YAN JIALONG MECHANICAL TECHNOLOGY (JIANGSU) CO., LTD.

厂址：常州市天宁区郑陆镇焦溪工业园区 Add: Jiaoxi Industrial Park, Zhenglu Town,
Tianning District, Changzhou City
手机：13775100691 Mob: +86-13775100691
电话：0519-88900958 88910958 Tel: +86-519-88900958 88910958
传真：0519-85853090 88912691 Fax: +86-519-85853090 88912691
官网：www.yjlgz.cn Web: www.yjlgz.cn
邮箱：sales@yjlgz.cn E-mail: sales@yjlgz.cn

注：1. 本公司对本样本所涉及内容拥有版权，未经授权，不得翻印，违者必究；
2. 本公司保留对产品改进的权利，恕不另行通知。

1. We owns the copywrite of the contents of this catalogue, any copy without authorization should be prosecuted.
2. We reserves the right to amend the contents of this catalogue without notice.

特别警告：对于易燃易爆物料的干燥，未经本公司许可，本公司不承担相关责任。
Warning: For to dry flammable or explosive material, our company will not bear any responsibility if without our special agreement.

燕加隆机械科技（江苏）有限公司
YAN JIALONG MECHANICAL TECHNOLOGY (JIANGSU) CO., LTD.



关于燕加隆

ABOUT YANJIALONG

燕加隆机械科技（江苏）有限公司是一家专业从事蒸发（浓缩）结晶成套设备的服务商。秉承“回收利用每一滴水”的美好愿景，始终专注于蒸发器技术产品的研发、设计、制造，拥有最强技术团队。

燕加隆是目前国内拥有多效蒸发器中试装备、降膜蒸发器中试装备、MVR蒸发器中试装备全系列中试装备的蒸发器高新科技企业。目前公司拥有比较大的蒸发器研发生产基地，有自己的生产车间和化验试验设备，可以及时为客户进行物料分析。

燕加隆公司拥有10年以上的从试验、设计、加工、安装、调试及售后一条龙服务的工程经验和业绩，专业技术团队30余人。公司通过ISO9001质量认证体系，获得高新技术企业证书，拥有各类发明和实用新型专利多项，其中许多技术达到国内领先水平，公司致力于让水更清，天更蓝，让环境更优美的神圣事业，竭力为新老客户服务，为中国环保事业做贡献。

选择我们的理由：

我们的理念：“诚信为本、实力为先，全心全意为客户”，我们公司秉承客户至上、服务至上的经营理念，以卓越的服务品质、专业的技术服务实力、技术精湛的安装售后服务团队，尽最大努力保障客户需求。

我们为企业提供功能强大服务，包括从物料研究，制定专属设计方案，产品生产以及安装调试包括处理售后问题。我们的工程师不仅经验丰富，而且随时能获得公司强大的技术支持，保障用户系统正常运行。

公司运用于各大领域的成功案例：

制造领域：航发集团、沈阳国泰飞机制造厂，辽宁博翔科技有限公司，江苏瑞声科技有限公司，江苏雷利电机集团等

化工领域：白银市伊博化工科技有限公司，沈阳联盛化工有限公司等

制药领域：山东世纪阳光科技有限公司，山东轩德医药科技有限公司，南阳普康恒旺药业有限公司，烟台宁远药业有限公司等

生物领域：成都生物制品研究所，江苏诺恩作物科学股份有限公司，诺维信（中国）生物技术有限公司等
还有涉及煤矿行业和电镀行业、新材料行业等各种不同领域

Yanjialong Machinery Technology (Jiangsu) Co., Ltd. is a service provider specializing in complete sets of evaporation (concentration) crystallization equipment. Adhering to the beautiful vision of "recycling every drop of water", we always focus on the research and development, design and manufacture of evaporator technology products, and have the strongest technical team.

Yanjialong is an evaporator high-tech enterprise with a full range of pilot equipment, including multi-effect evaporator pilot equipment, falling film evaporator pilot equipment and MVR evaporator pilot equipment. At present, the company has a relatively large evaporator R&D and production base, with its own production workshop and laboratory test equipment, which can analyze materials for customers in time.

Yanjialong Company has more than 10 years' engineering experience and achievements in testing, design, processing, installation, commissioning and after-sales one-stop service, with more than 30 professional and technical teams. Our company has passed the ISO9001 quality certification system, obtained the certificate of high-tech enterprise, and has many patents of various inventions and utility models, many of which have reached the domestic leading level. Our company is committed to the sacred cause of making the water clearer, the sky bluer and the environment more beautiful, and strives to serve the old and new customers and make contributions to China's environmental protection cause.

Reasons for choosing us:

Our philosophy: "Integrity-based, strength first, customer wholeheartedly", our company adheres to the business philosophy of customer first, service first, with excellent service quality, professional technical service strength, skilled installation and after-sales service team, and makes every effort to ensure customer demand.

We provide powerful services for enterprises, including material research, making exclusive design scheme, product production, installation and debugging, including dealing with after-sales problems. Our engineers are not only experienced, but also can get strong technical support from the company at any time to ensure the normal operation of the user system.

Successful cases of the company applied in various fields:

Manufacturing fields: Hangfa Group, Shenyang Guotai Aircraft Manufacturing Plant, Liaoning Boxiang Technology Co., Ltd., Jiangsu Ruisheng Technology Co., Ltd., Jiangsu Raleigh Electric Group, etc.

Chemical field: Baiyin Yibo Chemical Technology Co., Ltd., Shenyang Liansheng Chemical Co., Ltd.

Pharmaceutical fields: Shandong Century Sunshine Technology Co., Ltd., Shandong Xuande Pharmaceutical Technology Co., Ltd., Nanyang Pukang Hengwang Pharmaceutical Co., Ltd., Yantai Ningyuan Pharmaceutical Co., Ltd.

Biological field: Chengdu Institute of Biological Products, Jiangsu Nuoen Crop Science Co., Ltd., Novozymes (China) Biotechnology Co., Ltd.

There are also various fields such as coal mining industry, electroplating industry and new materials industry

公司证书

COMPANY CERTIFICATE





公司荣誉 COMPANY HONOR

多年来，公司秉承“诚信、品质、服务”的经营理念，现公司已取得ISO9001资格，并取得蒸发器，MVR蒸发器等多项专利权利。坚持以质量为企业的生命，坚持变革创新确保企业永远充满活力，给未来发展创造更多机会，也得到社会各界认可。

Over the years, the company has been adhering to the business philosophy of "integrity, quality and service". Now the company has obtained ISO9001 qualification and obtained many patent rights such as evaporator and MVR evaporator. Persisting in taking quality as the life of an enterprise, persisting in reform and innovation, ensuring that the enterprise is always full of vitality, creating more opportunities for future development, and being recognized by all sectors of society.

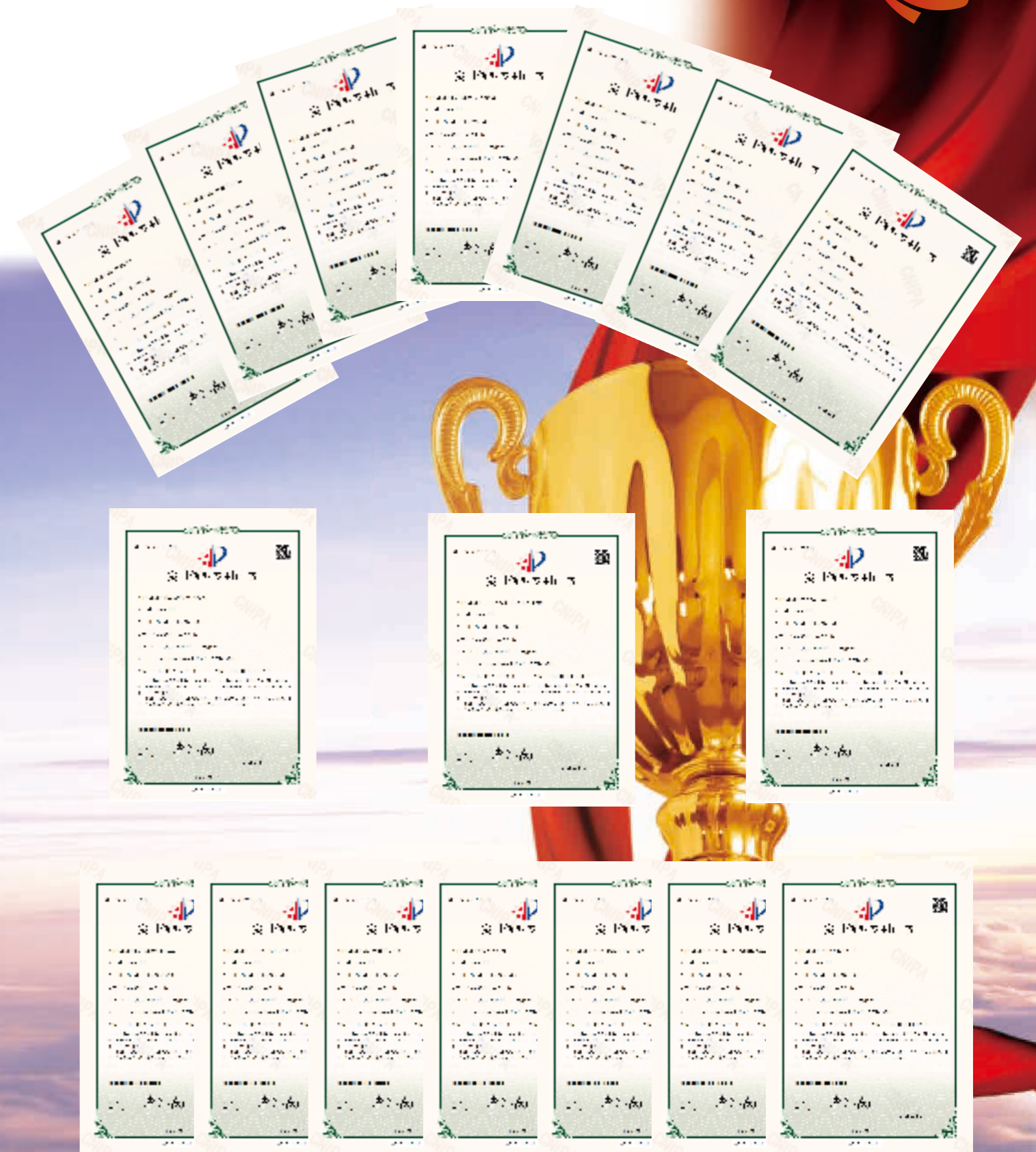



典型客户

TYPICAL CUSTOMER

辐射全国 放眼世界

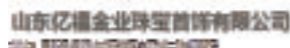

瑞声科技
RAC TECHNOLOGIES



宏源药业





Self-circulating Evaporation Unit 自循环蒸发机组

概述 Descriptions

蒸发浓缩是食品工厂使用最广泛的浓缩方法。采用蒸发浓缩设备把物料加热，使物料的易挥发部分水分和其他介质在其沸点温度时不断地由液态变为气态，并将汽化时所产生的二次蒸汽不断排除，从而使制品的浓度不断提高，直至达到浓度要求。

Is the most widely used food factory evaporating concentration method. Evaporation and concentration equipment adopts the heating material, volatile part of the moisture of material at its boiling point temperature and other media constantly changed from liquid to gas, secondary steam produced during the change will vaporize out constantly, so that the concentration of the products continue to improve, to meet the requirements of concentration.



应用范围 Application

广泛用于医药、食品、化工、轻工等行业的水或有机溶媒溶液的蒸发浓缩。特别适用于热敏性物料，在真空条件下进行低温连续浓缩。

This equipment is widely used in the evaporating and concentrating of water or organic solvents in pharmaceutical, food, chemical and light industries. It is especially suitable for low-temperature continuous concentration of thermo sensitive materials under vacuum condition.



特点 Features

- ◆本设备采用列管式循环外加热工作原理，物料受热时间短、蒸发速度快，有效保持物料原效。
- ◆节能效果显著，比单效蒸发器节约蒸汽量60%。物料在密闭系统中蒸发浓缩，环境清洁舒适；且本系统设备独特的除沫装置，防止跑料现象。
- ◆凡与物料接触部分均采用各类不锈钢制作，并进行抛光处理，设备耐腐蚀性好，列管不易堵，清洗更方便，更符合制药，食品卫生法规要求。可配微机控制系统，使用更简便，效果更稳定。
- ◆The equipment adopts the working principle of tube-type circulating external heating, which has short heating time and fast evaporation speed, and effectively keeps the original effect of materials.
- ◆There is an obvious energy-saving effect and 60% of steam is saved compared to the single effect evaporator. The material is evaporated and concentrated in the sealing system and enjoyed the clean and comfortable environment. And this system has unique entrainment eliminating device to prevent the material from leaking.
- ◆All parts in contact with materials are made of various stainless steels and polished. The equipment has good corrosion resistance, and the tubes are not easy to be blocked. It is more convenient to clean and more in line with the requirements of pharmaceutical and food hygiene regulations. It can be equipped with microcomputer control system, which is easier to use and more stable in effect.



Single-effect Forced Circulation Crystallization Evaporator

单效强制循环结晶蒸发器

概述 Descriptions

强制循环蒸发器是我公司开发研制的低耗节能浓缩结晶设备，具有料液流速快、蒸发快、不易结垢等特性。强制循环蒸发器可分为单效、双效及多效蒸发器。

单效强制循环蒸发器组成：

单效强制循环蒸发器由一效加热室、蒸发结晶室、冷凝器、循环泵、真空及排水系统、气液分离室、二次蒸汽闪蒸罐、盐分离器、操作平台、检测仪表及电气仪表控制柜及阀门及管道系统等组成。

Forced circulation evaporator is a low-consumption and energy-saving concentrating and crystallizing equipment developed by our company, which has the characteristics of fast flow rate of feed liquid, fast evaporation and difficult scaling. Forced circulation evaporators can be divided into single-effect, double-effect and multi-effect evaporators. Composition of single-effect forced circulation evaporator:

The single-effect forced circulation evaporator consists of a first-effect heating chamber, an evaporation crystallization chamber, a condenser, a circulating pump, a vacuum and drainage system, a gas-liquid separation chamber, a secondary steam flash tank, a salt separator, an operation platform, detection instruments and electrical instrument control cabinets, valves and pipeline systems, etc.

特点 Features

- 1、全套系统设计合理美观、运行稳定，强制循环式，使粘度较大的料液容易流动蒸发。
- 2、特殊设计经简单操作可实现切换改效，以适应不同产品的生产；
- 3、蒸发温度低，热量得到充分利用，料液受热温和，适用于热敏性物料的浓缩；
- 4、蒸发器通过强制循环，在管内受热均匀，传热系数高，可防止干壁现象；
- 5、料液进入分离器再分离，强化了分离效果，使整体设备具有较大的操作弹性；
- 6、连续进出料，料液液位与所需浓度可实现自控；
- 7、整套设备结构紧凑，占地面积小，布局简单流畅，代表了大型成套蒸发设备的发展方向。

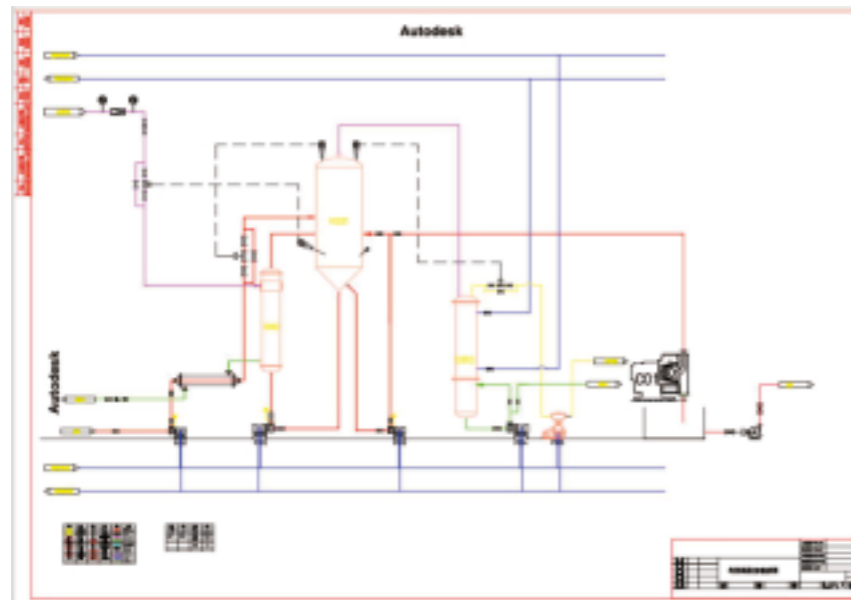

Double-effect Forced Circulation Crystallization Evaporator

双效强制循环结晶蒸发器

概述 Descriptions

双效强制循环蒸发器是由两个加热室组成。

强制循环蒸发器组成：

双效强制循环蒸发器由各效加热室、蒸发结晶室、冷凝器、循环泵、真空及排水系统、气液分离室、二次蒸汽闪蒸罐、盐分离器、操作平台、检测仪表及电气仪表控制柜及阀门及管道系统等组成。

The double-effect forced circulation evaporator consists of two heating chambers.

Composition of forced circulation evaporator:

The double-effect forced circulation evaporator consists of each effect heating chamber, evaporation crystallization chamber, condenser, circulating pump, vacuum and drainage system, gas-liquid separation chamber, secondary steam flash tank, salt separator, operation platform, detection instrument and electrical instrument control cabinet, valves and pipeline system, etc.

应用范围 Application

强制循环式蒸发器，适用于有结垢性、结晶性、热敏性(低温)、高浓度、高粘度并且含不溶性固形物等化工、食品、制药、环保工程、废液蒸发回收等行业的蒸发浓缩。

Forced circulation evaporator is suitable for evaporation and concentration in chemical industry, food industry, pharmaceutical industry, environmental protection engineering, waste liquid evaporation and recovery industry, etc., which has scale, crystallinity, heat sensitivity (low temperature), high concentration, high viscosity and insoluble solids.

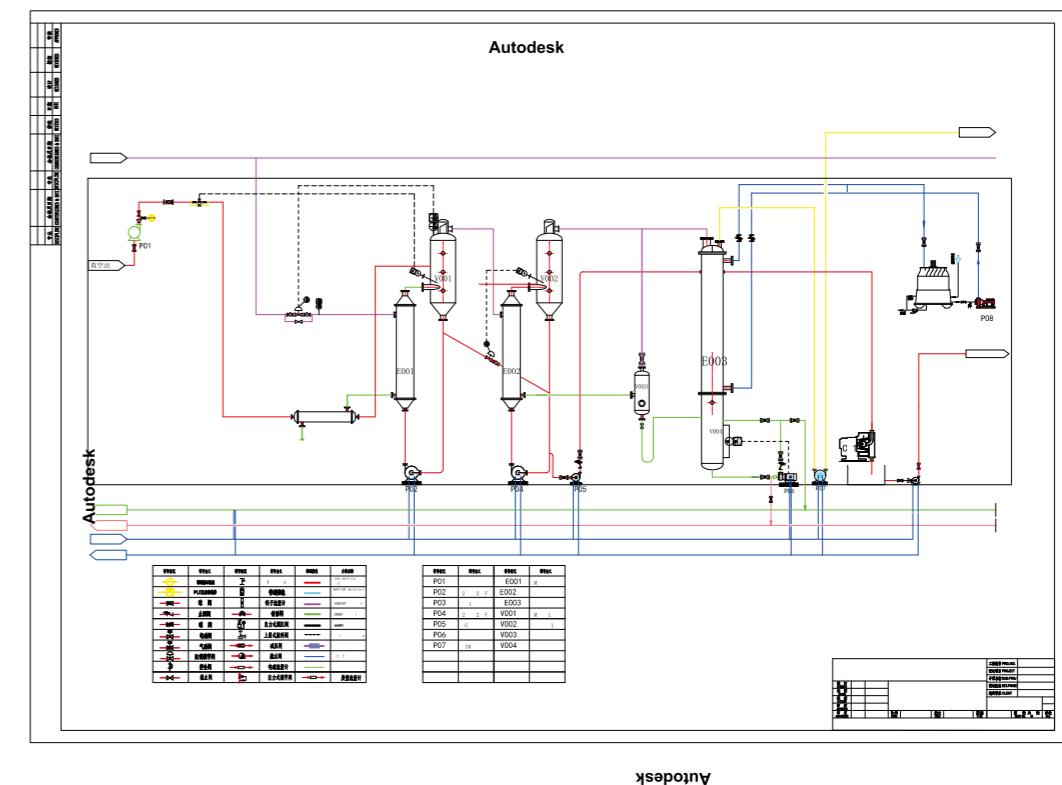



Three-effect Forced Circulation Crystallization Evaporator

三效强制循环结晶蒸发器

应用范围 Application

三效强制循环式蒸发器，适用于有结垢性、结晶性、热敏性(低温)、高浓度、高粘度并且含不溶性固形物等化工、食品、制药、废液蒸发回收等行业的蒸发浓缩。

特点 Features

1. 设备相对处理的物料特性适应范围广。其中主要针对蒸发过程容易结垢的物料、蒸发过程有晶体析出的物料、随着浓缩浓度提高，粘度相应增加的物料、有不溶性固形物的物料等；
2. 在蒸发过程中，物料加热通过强制循环，在管内流动速度快、受热均匀、传热系数高、并可防止干壁现象。
3. 料液通过强制循环泵快速经加热器加热，顶部出来直接切线式进入蒸发分离器，汽液分离效果好。
4. 物料通过设备蒸发浓缩，抽真空低温蒸发浓缩，加上连续式进出料，加热蒸发时间短，适应于食品酱料物料的热敏性蒸发浓缩。
5. 设备结构紧凑、占地面积小，布局流畅、操作方便、性能稳定等。
6. 设备可配置自动化系统，实现进料量自动控制，加热温度自动控制，出料浓度自动控制，还可配备突发停电、故障时对敏感性物料的保护措施，其它报警等自动化操作、控制。

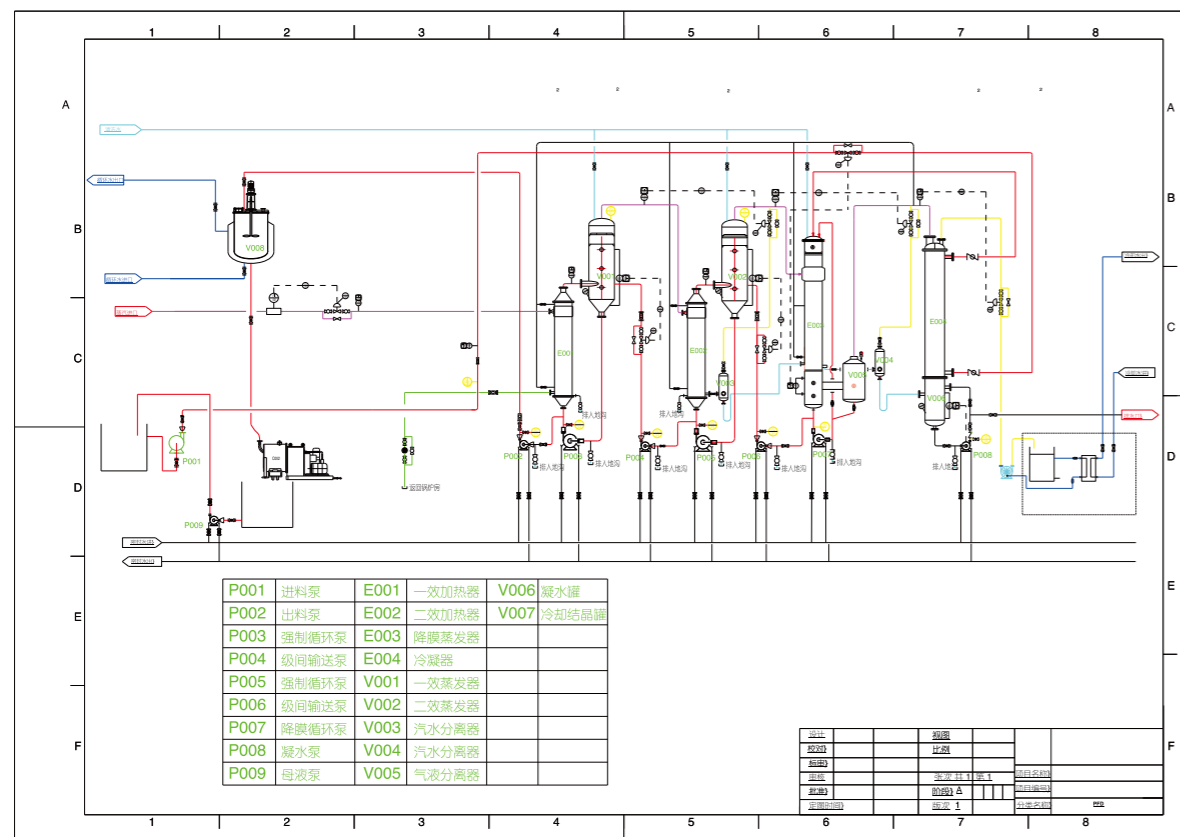

MVR Evaporator

MVR蒸发机组

概述 Descriptions

MVR蒸发器 (mechanical vapor recompression) 的简称。mvr是重新利用它自身产生的二次蒸汽的能量，从而减少对外界能源的需求的一项技术。

二次蒸汽，经过压缩机的压缩，压力和温度得以升高，热焓随之增加，被送到蒸发器的加热室当作加热蒸汽即生蒸汽使用，使料液维持蒸发状态，而加热蒸汽本身将热量传递给物料本身冷凝成水。这样，原来要废弃的蒸汽就得到了充分的利用，回收了潜热，又提高了热效率。

早在60年代，德国和法国已经成功的将该技术应用于化工、制药、造纸、污水处理、海水淡化等行业。

其工作过程是低温位的蒸汽经压缩机压缩，温度、压力提高，热焓增加，然后进入换热器冷凝，以充分利用蒸汽的潜热。除开车启动外，整个蒸发过程中无需生蒸汽。

多效蒸发过程中，蒸发器某一效的二次蒸汽不能直接作为本效热源，只能作为次效或次几效的热源。如作为本效热源必须额外给其能量，使其温度(压力)提高。蒸汽喷射泵只能压缩部分二次蒸汽，而mvr蒸发器则可压缩蒸发器中所有的二次蒸汽。

溶液在一个降膜蒸发器里，通过物料循环泵在加热管内循环。初始蒸汽用新鲜蒸汽在管外给热，将溶液加热沸腾产生二次汽，产生的二次汽由涡轮增压风机吸入，经增压后，二次汽温度提高，作为加热热源进入加热室循环蒸发。正常启动后，涡轮压缩机将二次蒸汽吸入，经增压后变为加热蒸汽，就这样源源不断进行循环蒸发。蒸发出的水分最终变成冷凝水排出。



应用范围 Application

本设备适用于制药、生物、食品、化工等行业，常用于中药提取液、果汁、精细化工溶液、废水等蒸发浓缩。

特点 Features

- (1) 低能耗、低运行费用。理论上，使用MVR蒸发器比传统蒸发设备可节省80%以上的能源;实际上，蒸发1000kg水分所需的能量仅为是传统蒸发器的1/6到1/5 (注:当物料不同时，能耗有所改变)，其运行成本也显著降低，一般只有传统蒸发器的35~50%。
- (2) 设备紧凑，占地面积小。与多效蒸发相比，可以减少50%以上的占地面积
- (3) 配套公用工程少。MVR的加热室就是蒸汽冷凝器，它无需单独设置蒸汽冷凝器以及庞大的循环冷却水系统，可以节省90%以上的冷却水。
- (4) 主要使用电能。除设备启动阶段需要少量工业蒸汽加热外，正常运行过程中只需要清洁型的电能，而无需工业蒸汽。
- (5) 运行平稳、自动化程度高。MVR系统通过DCS/PLC、工业计算机与组态软件的形式来控制系统温度、压力与转速等，保持系统蒸发平衡。
- (6) 采用单级真空蒸发，蒸发温度低(45~85℃)，特别适用于热敏性物料蒸发的浓缩。



工作原理 Principle of work

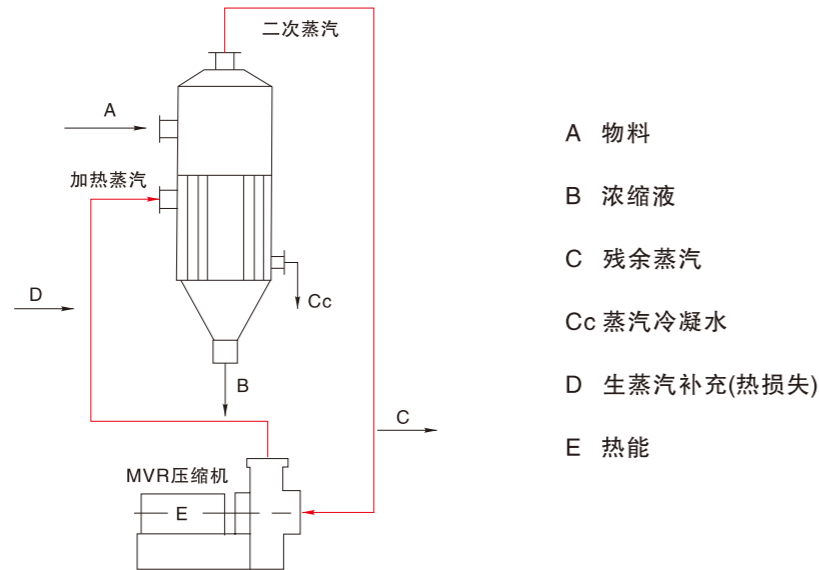

- (1) 用电能使蒸发产生的二次蒸汽被压缩，而且被充分利用，蒸汽在系统内几乎无损失
- (2) 将冷凝水和浓缩液输出热能与原液进行热交换
- (3) 不凝气与原液进行换热
- (4) 压缩机电机采用转速变频控制

MR技术可以将需要冷凝的二次蒸汽通过压缩机将蒸汽压缩到较高压力，因而内能得以提高，从而实现这股能量的持续循环，再次利用，以替代新鲜蒸汽。使用极少量的电能，使大量的低压蒸汽内能得以重新利用。减少或不需要供应生蒸汽、回收废热蒸汽、减少冷却水、提高系统利用效率的目的。

多效蒸发与MVR能耗对比（与10吨每小时三效对比）

	蒸汽		电		总费用
	使用量（度）	费用（元）	使用量（度）	费用（元）	
三效	5	1000	100	70	1070
MVR	0.2	40	500	350	390
每吨水节约					680

按蒸汽200元/吨，电费0.7元/度，一年300天，一天20小时计算。

MVR evaporating and crystalizing system

MVR（机械蒸汽压缩）蒸发结晶系统

概述 Descriptions

MVR蒸发系统使用压缩风机将蒸发系统中形成的二次蒸汽压缩升压，压缩后的二次蒸汽的冷凝温度升高可作为蒸发系统的热源。在合适的条件下，系统不需要补充生蒸汽完成蒸发；当进料温度低于系统的蒸发温度，当无法从浓缩液和系统产生的冷凝水中回收足够热能时，需要补充少量生蒸汽用于将物料预热到沸点。通常蒸发一吨水压缩风机的能耗在15KW~30KW范围内；根据物料特性，也会低于或高于这个范围。

The MVR evaporation system uses a compression fan to compress and boost the secondary steam formed in the evaporation system, and the increased condensation temperature of the compressed secondary steam can be used as the heat source of the evaporation system. Under suitable conditions, the system does not need to supplement raw steam to complete evaporation; When the feed temperature is lower than the evaporation temperature of the system, and when enough heat energy cannot be recovered from the concentrated solution and the condensed water produced by the system, a small amount of raw steam needs to be supplemented to preheat the materials to the boiling point. Usually, the energy consumption of compressor fan for evaporating one ton of water is in the range of 15KW~30KW. Depending on the material characteristics, it will also be lower or higher than this range.

特点 Features

- ◆ 少量生蒸汽
- ◆ 低能耗、低运行费用
- ◆ 可与结晶器组合，做成MVR形式的连续结晶器

- ◆ A small amount of raw steam
- ◆ Low energy consumption and low operating cost
- ◆ It can be combined with crystallizer to make continuous crystallizer in MVR form



制造范围 Manufacturing range

化学和制药工业 Chemical and pharmaceutical industries

酒精 苯酚、甲醇、乙醇、丁醇、甘油、乙二醇

制药溶液 酶、抗生素、药品萃取物、糖代用品、山梨醇、山梨糖、葡糖酸盐

Alcohol: phenol, methanol, ethanol, butanol, glycerol and ethylene glycol

Pharmaceutical solutions: enzymes, antibiotics, drug extracts, sugar substitutes, sorbitol, sorbose and gluconate

食品工业 Food industry

乳制品 全脂和脱脂奶、炼乳、甜乳清和乳酸、黄油、乳蛋白、乳糖溶液

高蛋白汁 大豆乳清、酵母提取物和饲料酵母

果汁 橙汁和其他柑橘汁、苹果汁和其他苹果汁、混合果汁、热带水果汁

蔬菜汁 生菜汁、甜菜根汁、番茄汁、胡萝卜汁

淀粉产品 葡萄糖、右旋糖、左旋糖、麦芽糖、淀粉糖浆、糊精

糖 甜菜糖、液体糖、精制白糖、甜水

提取物 肉和骨提取物、咖啡和茶提取物、蛇麻草提取物、麦芽提取物、酵母提取物、果胶

水解物质 乳清水解物、调味料液、蛋白水解物

Dairy products: Whole and skim milk, condensed milk, sweet whey and lactic acid, butter, milk protein and lactose solution;

High protein juice: Soybean whey, yeast extract and feed yeast

Juice: Orange juice and other citrus juice, apple juice and other apple juice, mixed juice, tropical fruit juice

Vegetable juice: Lettuce juice, beetroot juice, tomato juice, carrot juice

Starch products: Glucose, dextrose, levoglucose, maltose, starch syrup and dextrin

Sugar: Beet sugar, liquid sugar, refined white sugar, sweet water

Extracts: Meat and bone extract, coffee and tea extract, hop extract, malt extract, alcohol extract and pectin

Hydrolyzed substances: Whey hydrolysate, seasoning liquid, protein hydrolysate

连续结晶器应用范围 Application range of continuous crystallizer

乳糖、氯酸钾、氯环乙烷碳酸钠、亚硝酸钠、溴化铵、柠檬酸、硫酸铵、氯化钾、氯酸钠、过硼酸钠、氯铵、氯化铜、氯化镁、重铬酸钾、氯化钠、高氯酸钠、硫酸铵、硫酸铜葡萄糖、硫酸镁、高锰酸钾、铬酸钠、磷酸钠、硫代硫酸、钠二氯苯苹果酸、磷酸钾、氯化钠、水杨酸钠、抗坏血酸维生素C、双氰胺、甲硫氨酸、硫酸钾、重铬酸钠、硫酸钠、双酚A、二异丙醚醋酸镍、水杨酸及盐、连二亚硫酸钠、酒石酸钠、咖啡因、废水回收硫酸、硝酸镍、硝酸银、氯化钠、硫氰酸钠、氯化钙、铁、季戊四醇、乙酸钠、甲酸钠、硫酸锌、甲酸钙、丁烯二酸盐、溴化钾、坑坏血钠、谷氨酸钠、乙酰水杨酸钠、酒石酸钙、谷氨酸、碳酸钾、硝酸钾、铜古洛糖酸、酯肪铵、光卤石

Lactose, potassium chlorate, chlorocyclohexane sodium carbonate, sodium nitrite, ammonium bromide, citric acid, ammonium sulfate, potassium chloride, sodium chlorate, sodium perborate, ammonium hydrogen, copper chloride, magnesium chloride, potassium dichromate, sodium chloride, sodium perchlorate, ammonium sulfate, copper sulfate glucose, magnesium sulfate, potassium permanganate, sodium chromate, sodium phosphate, thiosulfuric acid, sodium dichlorobenzene malic acid, potassium phosphate, sodium chloride, etc Sodium dichromate, sodium sulfate, bisphenol A, nickel diisopropyl ether acetate, salicylic acid and salt, sodium hydrosulfite, sodium tartrate, caffeine, waste water recovery sulfuric acid, nickel nitrate, sodium fluoride, sodium thiocyanate, calcium chloride, iron, pentaerythritol, sodium acetate, sodium formate, zinc sulfate, calcium formate, butene diacid, potassium bromide, pit bad blood sodium, sodium glutamate, etc.

工艺流程 Technological Process

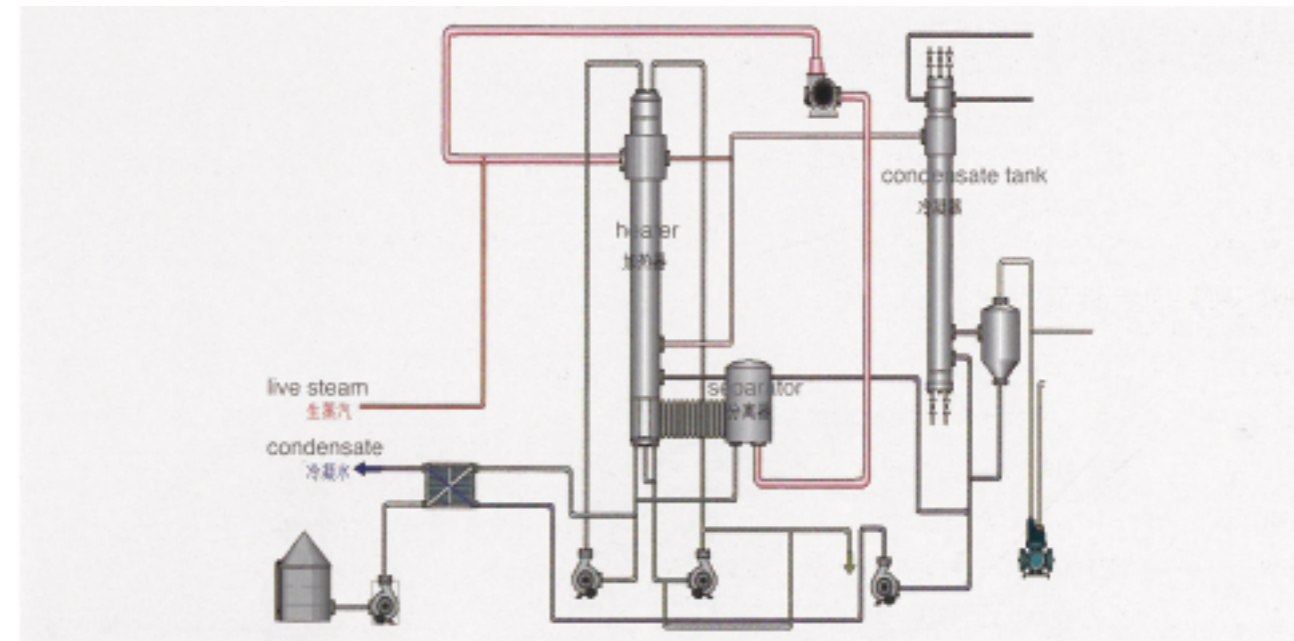

工艺案例 Project Cases





Falling film evaporator

降膜蒸发器

概述 Descriptions

在降膜蒸发系统中，物料呈膜状覆盖整个换热管内壁，沿换热管向下流动同时蒸发。即使在蒸发温差较低的情况下仍有可能获得较高的传热系数。换热管中部充满物料蒸发形成的二次蒸气，设计中可以根据情况选择二次蒸气与物料在换热管中同向或逆向流动。离开换热管的二次蒸气然后进入分离器完成汽液分离。分离器可采用常规的离心式或冲击式；可以设计为独立于降膜加热器的分体式，也可以是与加热器集成的一体式。一体式的设计可以缩小占地空间，降低安装成本。蒸发有轻微结垢问题的物料需要采用循环蒸发；即使物料循环，采用降膜设计也比强制循环节能很多。热敏的物料可采用直流程降膜设计以缩短物料停留时间，同时降低泵的能耗。降膜蒸发系统适用于处理没有结垢问题或结垢系数低的物料，通常不能用来结晶。但根据蒸发物料的特性，可以在设计中合并降膜与强制循环两种形式，用于处理有结垢问题的物料和连续结晶系统。在MVR（机械蒸汽压缩）和TVR（蒸汽动力热泵）设计中，低蒸发温差可以降低电耗和蒸汽消耗，降膜设计可以用于蒸发温差较低的情况，所以较适用于这类设计。受物料本身特性的影响或采用低温废热蒸发时（例如管束尾气或液化闪蒸汽），蒸发器内最高物料温度受到限制，与升膜相比采用降膜设计可放入更多效以降低能耗。降膜系统普遍应用于食品，制药，化工，造纸/制浆，和煤化工等行业。

In the falling film evaporation system, the material covers the inner wall of the whole heat exchange tube in a film shape, flows down the heat exchange tube and evaporates at the same time. Even if the evaporation temperature difference is low, it is still possible to obtain higher heat transfer coefficient. The middle part of the heat exchange tube is filled with secondary steam formed by evaporation of materials. In the design, the secondary steam and materials can flow in the same direction or reverse direction in the heat exchange tube according to the situation. Secondary steam leaving the heat exchange tube then enters the separator to complete vapor-liquid separation. The separator can be conventional centrifugal or impact type; It can be designed as a separate type independent of the falling film heater, or as an integrated type integrated with the heater. The integrated design can reduce the floor space and installation cost. Circulating evaporation is needed to evaporate materials with slight scaling problem; Even if materials are recycled, falling film design is much more energy-saving than forced recycling. Direct falling film design can be adopted for heat-sensitive materials to shorten the residence time of materials and reduce the energy consumption of pumps. Falling film evaporation system is suitable for treating materials with no scaling problem or low scaling coefficient, and usually cannot be used for crystallization. However, according to the characteristics of evaporated materials, falling film and forced circulation can be combined in the design to treat materials with scaling problems and continuous crystallization systems. In MVR (Mechanical Steam Compression) and TVR (Steam Power Heat Pump) design, low evaporation temperature difference can reduce power consumption and steam consumption, and falling film design can be used in the case of low evaporation temperature difference, so it is more suitable for this kind of design. Affected by the characteristics of materials or when low-temperature waste heat is used for evaporation (such as tube bundle tail gas or liquefied flash steam), the maximum material temperature in the evaporator is limited. Compared with the falling film design, more efficiency can be put in to reduce energy consumption. Falling film systems are widely used in food, pharmaceutical, chemical, paper/pulp, and coal chemical industries.

特点 Features

由于具有传热系数高，适应温差小，高真空蒸发的特点，可广泛利用低品质废热(如干燥机热空气及烟道气)，余热(冷凝水，过程水及其闪蒸汽)组成废热蒸发机组可少用或不用新鲜蒸汽而完成浓缩任务，实现蒸发用生蒸汽“零”的突破。具有传热效能高，温差小，无液柱引起的沸点损失、动力消耗少的优点。

With the characteristics of high heat transfer coefficient, small adaptive temperature difference and high vacuum evaporation, the waste heat evaporation unit composed of low-quality waste heat (such as dryer hot air and flue gas) and waste heat (condensed water, process water and its flash steam) can complete the concentration task with little or no fresh steam, thus realizing the breakthrough of "zero" raw steam for evaporation. It has the advantages of high heat transfer efficiency, small temperature difference, no boiling point loss caused by liquid column and less power consumption.

工艺流程 Technological Process

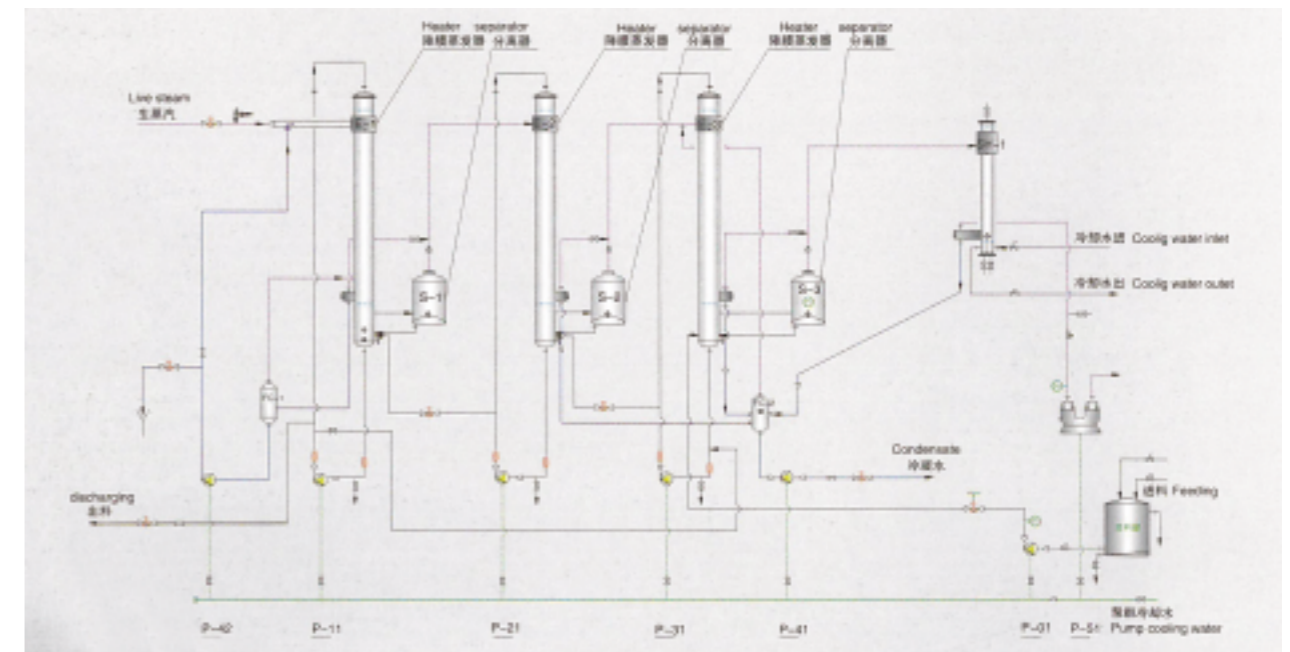



应用范围 Application

多效降膜蒸发器广泛应用于淀粉及衍生物行业、酒精行业、化工行业等的蒸发浓缩及结晶

Multi-effect falling film evaporator is widely used in evaporation concentration and crystallization of starch and derivatives industry, alcohol industry, chemical industry and so on

工艺案例 Project Cases



Forced Circulation Evaporation/crystallization System 强制循环蒸发/结晶系统

概述 Descriptions

在强制循环蒸发系统中物料通过循环泵在换热管中以1-3米/秒的速度流动，升温1-5° C。晶浆和易形成结垢物料在蒸发器换热管中的状态等同于他们在相同尺寸管道，相同流速下的运动状态，少量温度变化的产生的影响不明显。也就是说在同样条件下，如果物料能通过一个管道，就能通过蒸发器的换热管。强制循环系统配套的循环泵规格比降膜系统高出很多；对于结晶器，循环泵所需的扬程很低。强制循环蒸发系统抗结垢能力强于降膜系统，适用于易结垢的物料的浓缩或连续结晶。

根据蒸发物料的特性，可以在设计中合并降膜与强制循环两种形式，用于处理有结垢问题的物料和连续结晶系统。在降膜单元完成物料的预浓缩，然后进入强制循环单元完成最终浓缩或连续结晶，节约设备投入和运行费用。

In the forced circulation evaporation system, the material flows in the heat exchange tube at a speed of 1-3m/s through a circulating pump, and the temperature rises by 1-5 C .The state of crystal slurry and scaling-prone materials in evaporator heat exchange tubes is equivalent to their movement state in the same size pipes and at the same flow rate, and the influence of a small amount of temperature change is not obvious. That is to say, under the same conditions, if the material can pass through a pipe, it can pass through the heat exchange tube of the evaporator. The specification of circulating pump in forced circulation system is much higher than that in falling film system. For crystallizer, the head of circulating pump is very low. The anti-scaling ability of forced circulation evaporation system is stronger than that of falling film system, and it is suitable for concentration or continuous crystallization of materials easy to scale.

According to the characteristics of evaporated materials, falling film and forced circulation can be combined in the design to treat materials with scaling problems and continuous crystallization system. Pre-concentration of materials is completed in falling film unit, and then enters forced circulation unit to complete final concentration or continuous crystallization, saving equipment investment and operation cost.



特点 Features

具有浓缩物料范围广、浓缩比大、出料浓度高、充分抗积垢、抗堵塞的特点。

It has the characteristics of wide range of concentrated materials, large concentration ratio, high discharge concentration, full anti-fouling and anti-blocking.

工艺流程 Technological Process

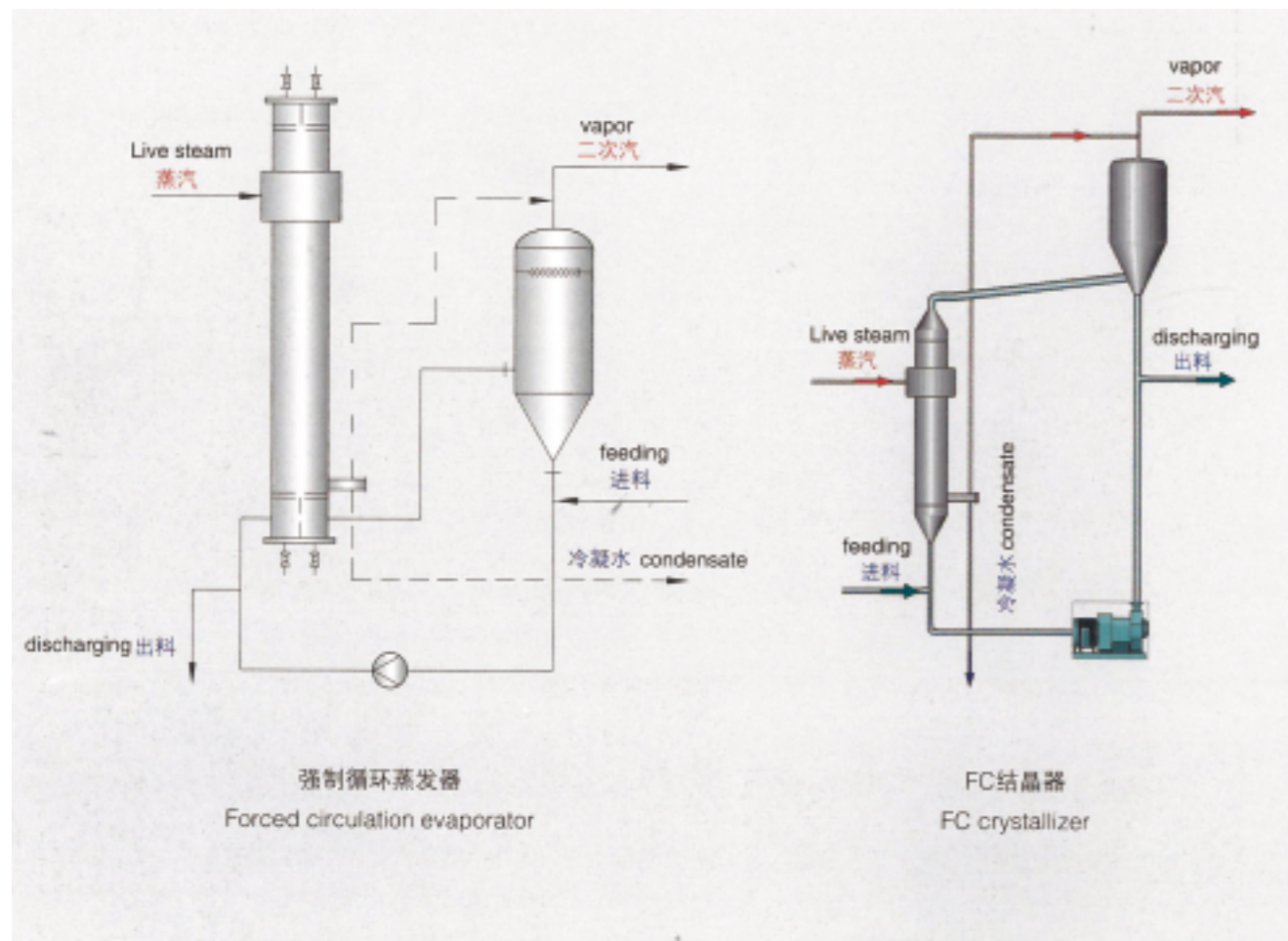

应用范围 Application

◆典型的浓缩使用范例

玉米浆、酒精废液、赖氨酸废液、谷氨酸废液、带菌体的发酵液、酵母废液、青霉素废液各类化工废水。

◆典型的结晶使用范例

Vc、柠檬酸、赖氨酸、苏氨酸及其它氨基酸、氯化钠、氯化铵、硫酸铵、硫酸钠、硫酸镁、磷酸钠、碳酸钠、碳酸铵、硝酸钠、氢氧化锂、碳酸锂。

◆ Typical examples of concentration

Corn steep liquor, alcohol waste liquor, lysine waste liquor, glutamic acid waste liquor, fermentation liquor with bacteria, yeast waste liquor and penicillin waste liquor.

◆ Typical crystallization usage examples

Vc, citric acid, lysine, threonine and other amino acids, sodium chloride, ammonium chloride, ammonium sulfate, sodium sulfate, magnesium sulfate, sodium phosphate, sodium carbonate, ammonium carbonate, sodium nitrate, lithium hydroxide and lithium carbonate.

工艺案例 Project Cases





Multi-effect evaporator 多效蒸发器



概述 Descriptions

多效蒸发器，由较原始的蒸发釜，发展成单效、双效、三效、四效或者更多效蒸发器，其目的都是为了逐渐减少能源消耗。

多效蒸发器是由相互串联的多个蒸发器组成。是利用前一效蒸发产生的二次蒸汽为下一效提供热源，来达到节能的目的。多效可以回收部分的二次蒸汽，效数越多回收的二次蒸汽越多。这一点有别于MVR蒸发器能够回收全部的二次蒸汽。

一般来说：三效蒸发每吨水消耗0.37~0.46吨蒸汽，四效蒸发每吨水消耗0.3~0.35吨蒸汽，五效蒸发每吨水消耗0.24~0.3吨蒸汽。

我们公司的多效蒸发系统，往往考虑回收冷凝水或二次蒸汽的热量，来实现节能的目的。在废水处理中，还要考虑预热器结垢的自动在线清洗。

多效蒸发器可以采用强制循环、自然循环、降膜、升膜、板式蒸发器等多种形式，也可以采用多种组合的方式，来较优化工艺。

多效蒸发的流程：可以有顺流、逆流、平流、错流等。

Multi-effect evaporators have been developed from primitive evaporation kettles to single-effect, double-effect, triple-effect, four-effect or more-effect evaporators, all of which are aimed at gradually reducing energy consumption.

The multi-effect evaporator is composed of a plurality of evaporators connected in series. The secondary steam produced by evaporation in the previous effect is used to provide heat source for the next effect, so as to achieve the purpose of energy saving. Multi-effect can recover part of secondary steam, and the more effects, the more secondary steam will be recovered. This is different from the fact that MVR evaporator can recover all the secondary steam.

Generally speaking, three-effect evaporation consumes 0.37~0.46 tons of steam per ton of water, four-effect evaporation consumes 0.3~0.35 tons of steam per ton of water, and five-effect evaporation consumes 0.24~0.3 tons of steam per ton of water.

The multi-effect evaporation system of our company often considers recovering the heat of condensed water or secondary steam to achieve the purpose of energy saving. In wastewater treatment, automatic on-line cleaning of preheater fouling should also be considered.

Multi-effect evaporators can adopt forced circulation, natural circulation, falling film, rising film, plate evaporator and other forms, and can also adopt various combinations to optimize the process.

Reactor 反应釜



电加热反应釜

不锈钢反应釜

概述 Descriptions

本设备应用于食品饮料、生化制药等行业中的溶解、混合、水解、中和、结晶、蒸馏、蒸发等生产过程。

我公司生产的反应釜有碳钢、不锈钢、搪瓷以及内衬防腐材料。

搅拌型式有桨式、锚式、框式、推进式、螺带式、磁力搅拌以及特殊搅拌型式；

加热冷却形式可采用整体夹套、半管夹套、蜂窝夹套、内盘管夹套等结构；

加热方式有蒸汽、电加热、导热油等；以满足耐酸碱、耐高温、耐磨损、抗腐蚀同工艺需要。

This equipment is applied to the dissolution of food and beverage, biochemical, pharmaceutical and other industries, mixed, hydrolysis, neutralization, crystallization, distillation, evaporation, etc. The production process.

Our company produces the reaction kettle is carbon steel, stainless steel, enamel and lining anticorrosive material.

Mixing type have a paddle, anchor, frame, pusher, screw conveyor, as well as special magnetic stirring type;

Can be used as a whole in the form of cooling heating jacket, half pipe jacket, honeycomb jacket, inside dish tube jacket structure;

Heating mode with steam, electric heating, heat conduction oil, etc.; In order to meet the acid and alkali resistance, high temperature, wear resistance, corrosion resistance with process needs.

技术参数 Technical parameters

型号规格	Specifications	FJ-500	FJ-1000	FJ-1500	FJ-2000	FJ-3000	FJ-5000	FJ-10000
公称容积(m ³)	The nominal volume (m3)	500	1000	1500	2000	3000	5000	10000
公称直径(mm)	Nominal diameter (mm)	800	1000	1200	1200	1400	1600	2200
釜内公称压力(Mpa)	Inside the kettle nominal pressure (Mpa)	< 10Paa						
夹套公称压力(Mpa)	Jacketed nominal pressure (Mpa)	< 10MPa						
电机功率(kw)	Motor power (kw)	2.2	3.0	4.0	4.0	5.5	7.5	18.5
容器类别	The container type	I、II类						



KLG Series Hollow Blade Dryer

KJG系列空心桨叶干燥机

概述 Descriptions

我公司在吸收国内外先进技术的基础上，进行改进、优化设计的楔型空心桨叶干燥机，可对膏状、颗粒状、粉状、浆状物料间接加热或冷却，可完成干燥、冷却、加热、灭菌、反应、低温煅烧等单元操作。设备中特殊的楔型搅拌传热桨叶，具有较高的传热效率和传热面自清洁功能。

空心轴上密集排列着楔型中空桨叶，热介质经空心轴流经桨叶。单位有效容积内传热面积很大，热介质温度从-40℃到320℃，可以是水蒸汽，也可以是液体型：如热水、导热油等。间接传导加热，没有携带空气带走热量，热量均用来加热物料。热量损失仅为通过器体保温层向环境的散热。楔型桨叶传热面具有自清洁功能。物料颗粒与楔型面的相对运动产生洗刷作用，能够洗刷掉楔型面上附着物料，使运转中一直保持着清洁的传热面。桨叶干燥机的壳体为W型，壳体内一般安排二到四根空心搅拌轴。壳体有密封端盖与上盖，防止物料粉尘外泄及收集物料溶剂蒸汽。出料口处设置一挡板，保证料位高度，使传热面被物料覆盖而充分发挥作用。热介质通过旋转接头，流经壳体夹套及空心搅拌轴，空心搅拌轴依据热介质的类型而具有不同的内部结构，以保证最佳的传热效果。

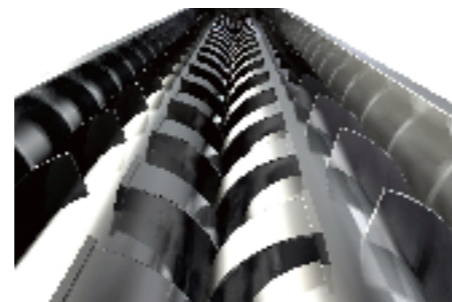

型号	KJG-2.7	KJG-9	KJG-13	KJG-18	KJG-24	KJG-29	KJG-36	KJG-41
传热面积m ² heat transfer area	2.7	9	13	18	24	29	36	41
有效容积m ³ effective volume	0.06	0.32	0.59	1.09	1.53	1.85	2.42	2.8
转速范围r.p.m revolution	15-30	10-25	10-25	10-20	10-20	10-20	10-20	10-20
功率kw power	2.2	3.8	5.5	7.5	11	11	15	15
器体宽A mm width of dryer body	306	584	762	940	1118	1118	1296	1296
总宽B mm total width	736	841	1066	1320	1474	1474	1676	1676
器体长C mm length of dryer body	1956	2820	3048	3328	3454	4114	4115	4724
总长D m tota length	2972	4876	5486	5918	6147	6808	6960	7570
进出料距E mm Distance bteveen feeding and discharging	1752	2540	2768	3048	3150	3810	3810	4420
中心高F mm height in center	380	380	534	610	762	762	915	915
总高G m tota height	762	838	1092	1270	1524	1524	1778	1778
进汽口N steam inlet	(2)3/4	(2)3/4	(2) 1	(2) 1	(2) 1	(2) 1	(2) 1	(2) 1
出水口O water outlet	(2)3/4	(2)3/4	(2) 1	(2) 1	(2) 1	(2) 1	(2) 1	(2) 1

型号	KJG-48	KJG-52	KJG-62	KJG-68	KJG-73	KJG-81	KJG-87	KJG-95	KJG-110
传热面积m ² heat transfer area	48	52	62	68	73	81	87	95	110
有效容积m ³ effective volume	3.54	3.96	4.79	5.21	5.78	6.43	7.39	8.07	9.46
转速范围r.p.m revolution	10-20	10-20	10-20	10-20	5-15	5-15	5-15	5-15	5-10
功率kw power	30	30	45	45	55	55	75	75	95
器体宽A mm width of dryer body	1474	1474	1651	1652	1828	1828	2032	2032	2210
总宽B mm total width	1854	1854	2134	2134	2286	2286	2438	2438	2668
器体长C mm length of dryer body	4724	5258	5410	5842	5461	6020	5537	6124	6122
总长D m tota length	7772	8306	8865	9296	9119	9678	9119	9704	9880
进出料距E mm Distance bteveen feeding and discharging	4420	4954	4953	5384	5004	5562	5080	5664	5664
中心高F mm height in center	1066	1066	1220	1220	1220	1220	1220	1220	1220
总高G m tota height	2032	2032	2362	2362	2464	2464	2566	2566	2668
进汽口N steam inlet	(2)11/2	(2)11/2	(2)11/2	(2)11/2	(2)11/2	(2)11/2	(2)2	(2)2	(2)2
出水口O water outlet	(2)11/2	(2)11/2	(2)11/2	(2)11/2	(2)11/2	(2)11/2	(2)2	(2)2	(2)2

注：部分参数设计时视不同物料有所调整，以设计为准。

工作原理 Principle of work

干化机主要由夹套，单轴转子和传动装置组成。固废通过夹套，空心轴和轴上焊接的空心盘片的热传到被间接加热干化。盘片对固废没有切割，而是通过盘片边缘的推进搅拌器的作用，对固废进行搅拌，不断更新干化面，从而实现干化的目的。

The drying machine is mainly composed of jacket, single shaft rotor and transmission device. The solid waste passes through the jacket, hollow shaft and heat transfer from the hollow disc welded to the shaft to be indirectly heated and dried. The disc does not cut solid waste, but mixes solid waste by pushing the agitator on the edge of the disc, and constantly updates the drying surface, so as to achieve the purpose of drying.



工作原理 Principle of work

